

# FURUNO

# INSTALLATION MANUAL

AUTOPILOT

---

MODEL NAVpilot-500/511/520

---

**NAV***pilot*

 FURUNO ELECTRIC CO., LTD.

[www.furuno.com](http://www.furuno.com)

All brand and product names are trademarks, registered trademarks or service marks of their respective holders.

**ECF**

(Elemental Chlorine Free)

The paper used in this manual  
is elemental chlorine free.

**FURUNO ELECTRIC CO., LTD.**

9-52 Ashihara-cho,  
Nishinomiya, 662-8580, JAPAN

• FURUNO Authorized Distributor/Dealer

All rights reserved. Printed in Japan

Pub. No. IME-72500-J2

(REFU ) NAVPILOT-500/511/520

A : APR. 2003

J2 : NOV. 28, 2011



\* 0 0 0 1 4 6 9 8 8 1 7 \*



# SAFETY INSTRUCTIONS



## WARNING

**Turn off the power at the switchboard before beginning the installation.**

Fire or electrical shock can result if the power is left on.

**Use the specified power cable.**

Use of other power cable may result in fire.

**Confirm that no one is near the rudder when bleeding air from oil cylinder.**

The rudder may move unexpectedly, possibly causing bodily injury.



## CAUTION

**Confirm that the power supply voltage is compatible with the voltage rating of the equipment.**

Connection to the wrong power supply can cause fire or equipment damage.

**Observe the following compass safe distances to prevent interference to a magnetic compass:**

		Standard compass	Steering compass
Control unit	FAP-5001	0.45 m	0.3 m
	FAP-5011	0.3 m	0.3 m
	FAP-5021	0.3 m	0.3 m
Processor unit		0.35 m	0.3 m
Remote controllers		0.3 m	0.3 m

# TABLE OF CONTENTS

---

<b>SYSTEM CONFIGURATION</b> .....	<b>iii</b>
<b>EQUIPMENT LISTS</b> .....	<b>iv</b>
<b>1. INSTALLATION OF UNITS</b> .....	<b>1-1</b>
1.1 Control Unit FAP-5001/5011 .....	1-1
1.2 Processor Unit FAP-5002.....	1-4
1.3 Rudder Reference Unit FAP-6112.....	1-5
1.4 Remote Controllers (option).....	1-6
1.5 Control Unit FAP-5021 .....	1-11
1.6 Junction Box (option) .....	1-12
<b>2. WIRING</b> .....	<b>2-1</b>
2.1 Wiring System .....	2-1
2.2 Processor Unit.....	2-2
2.3 Control Unit .....	2-7
2.4 Remote Controllers (option).....	2-8
2.5 Connection of Instruments FI-30.....	2-11
2.6 Input/Output Sentences .....	2-12
<b>3. ADJUSTMENTS</b> .....	<b>3-1</b>
3.1 How to Access the Installation Menu .....	3-1
3.2 DOCKSIDE SETUP Menu .....	3-2
3.3 SEA TRIAL Menu .....	3-11
3.4 DISPLAY SETUP Menu .....	3-16
3.5 DATA CALIBRATION Menu.....	3-18
3.6 Other Settings .....	3-20
<b>PACKING LISTS</b> .....	<b>A-1</b>
<b>OUTLINE DRAWINGS</b> .....	<b>D-1</b>
<b>INTERCONNECTION DIAGRAM</b> .....	<b>S-1</b>

# SYSTEM CONFIGURATION

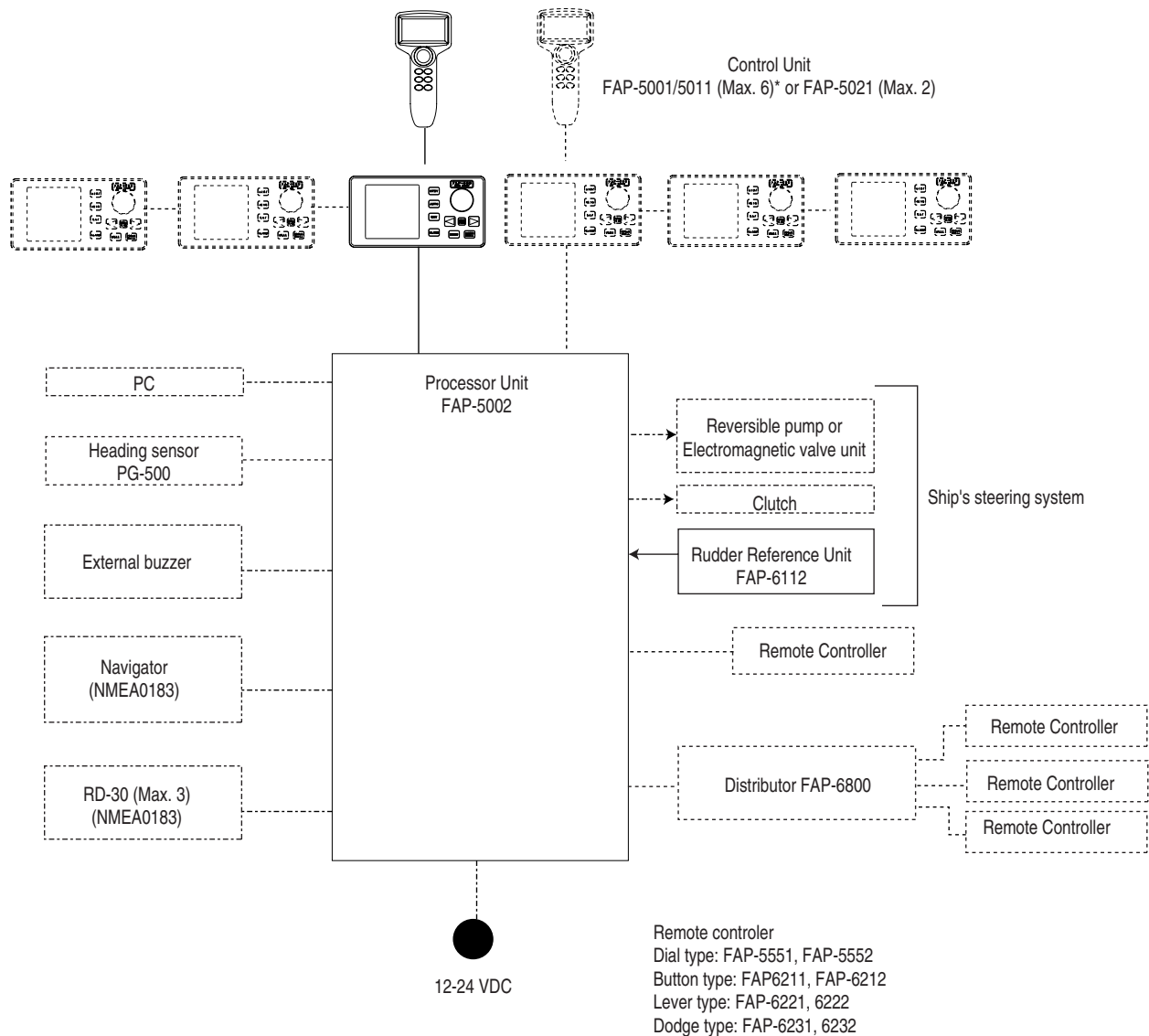

\*: Any combination of FAP-5001 and 5011 is available.  
Also, FAP-5021 can be connected at the end of series.

# EQUIPMENT LISTS

---

## Standard supply for Navpilot-500

Name	Type	Code No.	Qty	Remarks
Control Unit	FAP-5001-E	-	1	
Processor Unit	FAP-5002	-	1	
Rudder Reference Unit	FAP-6112-200	-	1	w/20 m cable
Installation Materials	CP64-02200	-	1 set	For Control Unit, MJ-A7SPF cable and CP64-02201
	CP64-02210	009-000-620	1 set	For Processor Unit, MJ-A7SPF cable and CP64-02211
	CP64-02601	009-001-170	1 set	For Rudder reference Unit
Spare Parts	SP64-01401	009-000-610	1 set	For Processor Unit, fuse
Accessories	FP64-01001	009-000-600	1 set	For Control Unit, terminator

## Standard supply for Navpilot-511

Name	Type	Code No.	Qty	Remarks
Control Unit	FAP-5011-E	-	1	
Processor Unit	FAP-5002	-	1	
Rudder Reference Unit	FAP-6112-200	-	1	w/20 m cable
Installation Materials	CP64-02400	009-000-580	1 set	For control unit, MJ-A7SPF cable and CP64-02401
	CP64-02210	009-000-620	1 set	For Processor unit
	CP64-02601	009-001-170	1 set	For Rudder reference unit
Spare Parts	SP64-01401	009-000-610	1 set	For Processor unit, fuse
Accessories	FP64-01001	009-000-600	1 set	For Control unit, terminator

### Standard supply for Navpilot-520

Name	Type	Code No.	Qty	Remarks
Control Unit	FAP-5021-E	-	1	
Processor Unit	FAP-5002	-	1	
Rudder Reference Unit	FAP-6112-200	-	1	w/20 m cable
Installation Materials	CP64-02210	009-000-620	1 set	For Processor unit
	CP64-02601	009-001-170	1 set	For rudder reference unit
Spare Parts	SP64-01401	009-000-610	1 set	For processor unit
Accessories	FP64-01201	009-000-890	1 set	For control unit

### Optional supply

Name	Type	Code No.	Qty	Remarks
Control Unit	FAP-5001-E	-	1	Max. 5 optional units
	FAP-5011-E	-		
	FAP-5021-E	-		Max. 1 optional unit
Remote Controller	FAP-5551-E	000-090-224	1 set	Dial type, w/connector
	FAP-5552-E	000-090-269	1 set	Dial type, no connector
	FAP-6211-E	000-090-235	1 set	Button type, w/connector
	FAP-6212-E	000-090-271	1 set	Button type, no connector
	FAP-6221-E	000-090-239	1 set	Lever type, w/connector w/CP64-01100
	FAP-6222-E	000-090-273	1 set	Lever type, no connector w/CP64-01100
	FAP-6231-E	000-090-251	1 set	Dodge type, w/connector
	FAP-6232-E	000-090-279	1 set	Dodge type, no connector
Distributor	FAP-6800	000-090-242	1 set	For 3 remote controllers connection
Cable Assy	MJ-A7SPF0010-100	000-147-018	1	w/ connector at one end, 10 m
	MJ-A7SPF0010-150	000-148-507	1	w/ connector at one end, 15 m
	MJ-A7SPF0010-200	000-148-508	1	w/ connector at one end, 20 m
	MJ-A7SPF0012-100	000-147-231	1	w/ connector at both ends, 10 m
Bracket	FP64-01011	009-000-330	1	For FAP-5001, w/a bracket and two knob bolts
	FP64-01101	009-000-670	1	For FAP-5011, w/a bracket and two knob bolts
Rudder Reference Unit	FAP-6112-200	-	1	w/20 m cable
Terminator	MJ-A7SPF0011	000-147-017	1	
Accessory	FP64-01201	009-000-890	1	Cradle
Junction Box	FAP-6821	000-090-411	1	w/self-tapping screws

This page is intentionally left blank.



# 1. INSTALLATION OF UNITS

---

## 1.1 Control Unit FAP-5001/5011

The control unit can be flush mounted in a console panel. For the FAP-5001, the desktop mounting is also available using the optional bracket kit.

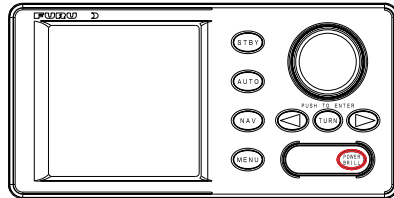

FAP-5001

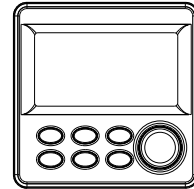

FAP-5011

*Control unit*

When selecting a mounting location for the control unit, keep the following in mind.

- The mounting location should be well ventilated.
- Mount the unit where shock and vibration are minimal.
- Use the supplied display hard cover when the system is not in use.
- Do not mount the display unit under “Plexiglas” or any other type of shielding which could trap heat and moisture or magnify sunlight energy onto the surface of the display.
- For maintenance and checking purposes, leave sufficient space at the sides and rear of the unit and leave slack in cables.
- A magnetic compass will be affected if the control unit is placed too close to the magnetic compass. Observe the compass safe distances to prevent disturbance to the magnetic compass.

FAP-5001: standard: 0.45 m, steering: 0.3 m.

FAP-5011: standard: 0.3 m, steering: 0.3 m

## 1. INSTALLATION OF UNITS

### 1.1.1 Flush mounting

Follow the procedure below to mount the control unit in a console panel.

1. Prepare a cutout in the mounting location using the template sheet supplied.
2. Attach the flush mounting sponge (supplied) to the control unit.
3. Screw four threaded rods (supplied) into holes on the back of the control unit tightly.
4. Pass four threaded rods screwed at step 2 through holes made at step 1, flat washers, spring washers and wing screws (supplied).
5. Screw four thumbscrews tightly.

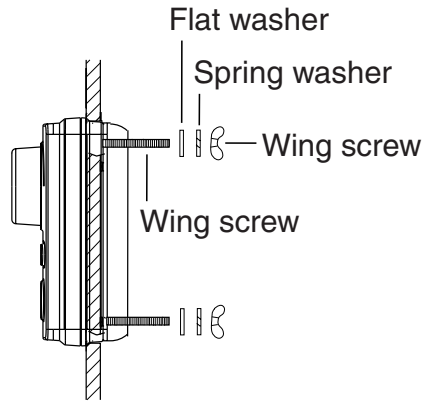

*Flush mounting of control unit*

## 1.1.2 Desktop mounting

Use the optional brackets to mount the control unit on a desktop or the overhead.

### For FAP-5001

Name: Bracket  
Type: FP64-01011  
Code No.: 009-000-330

Name	Type	Code No.	Qty
Bracket assembly	64-024-1502	100-305-820	1
Knob bolt	02-139-1032	100-298-472	2
Bracket	03-153-1155	100-288-890	2
Fixing plate	03-153-1155	100-288-890	2
Pan head screw	M4x10	000-881-964	4
		000-163-543-10	
Self-tapping screw	5x20	000-802-081	4
		000-162-605-10	

### For FAP-5011

Name: Bracket  
Type: FP64-01101  
Code No.: 009-000-670

Name	Type	Code No.	Qty
Bracket assembly	FP64-01102	009-000-700	1
Knob bolt	05-092-1071	100-312-221	2
Junction plate	64-026-1032	100-321-330	1
Pan head screw	M4x10	000-163-543-10	4
Self-tapping screw	4x16	000-162-605-10	4

### Procedure

1. Fix the bracket assembly to the mounting location with four self-tapping screws (supplied with option).
2. **For FAP-5001**, attach two brackets to the back of the control unit with four pan head screws (supplied with option). **For FAP-5011**, attach the junction plate to the back of the control unit with four pan head screws (supplied with option).
3. Screw knob bolts in brackets, set unit to bracket assembly, and tighten knob bolts.
4. Attach hard cover to protect the LCD.

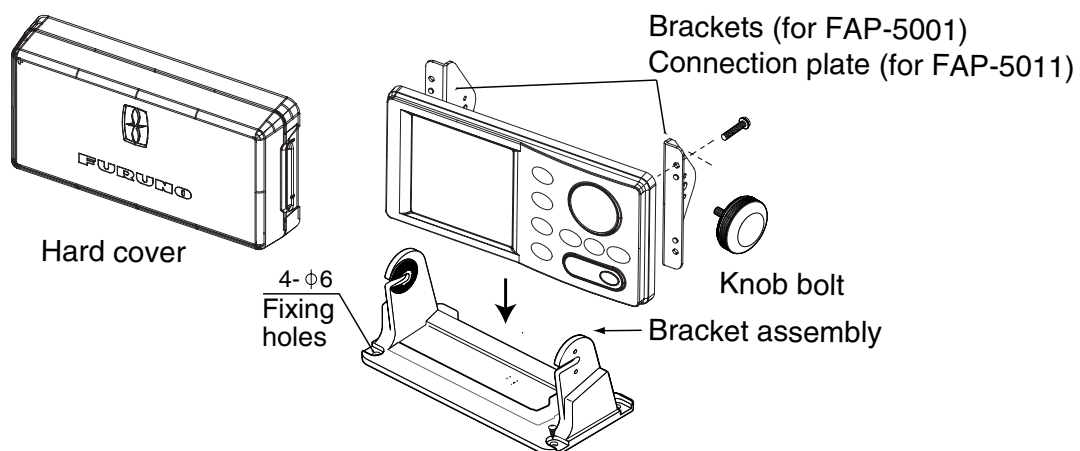

*Control unit, desktop mounting (ex. FAP-5001)*

**Note:** For FAP-5011, use the junction plate instead of the brackets.

## 1.2 Processor Unit FAP-5002

This unit can be mounted on a desktop or on a bulkhead. Select a mounting location considering the points below.

- Locate the unit out of direct sunlight and water splash.
- Select a location where temperature and humidity are moderate and stable.
- Consider the length of the cable connected between the processor unit and other units.
- Locate the unit where its cover can be removed and cabling easily accessed.
- For mounting on a bulkhead, be sure the mounting location is strong enough to support the unit under the pitching and rolling normally encountered on the vessel.
- Leave sufficient space around the unit for maintenance and servicing. Recommended maintenance space appears in the outline drawing at the back of this manual.
- A magnetic compass will be affected if the processor unit is placed too close to the magnetic compass. Observe the compass safe distances to prevent disturbance to the magnetic compass: standard: 0.35 m, steering: 0.3 m.

1. Unfasten five pan head screws to remove the cover.

2. Mount the unit as follows:

Tabletop: Fasten with four self-tapping screws.

Bulkhead mounting: Screw in four self-tapping screws in the mounting location, leaving 5 mm protruding. Set the processor unit to the screws and tighten screws.

3. Reattach the cover.

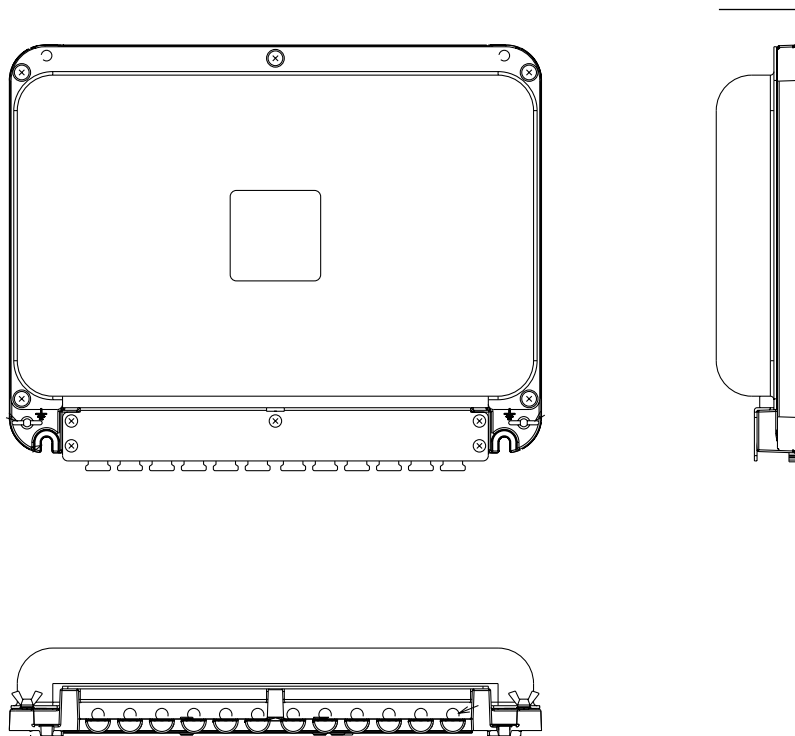

*Processor unit*

### 1.3 Rudder Reference Unit FAP-6112

- Leave sufficient space around all moving parts.
- The unit must be coupled to the rudder as shown below, where the following conditions are satisfied:

Use four self-tapping screws (supplied) to fasten the rudder reference unit.

$350 \text{ mm} < Y2 < 540 \text{ mm}$

$X1 = X2$

$Y1 = Y2$

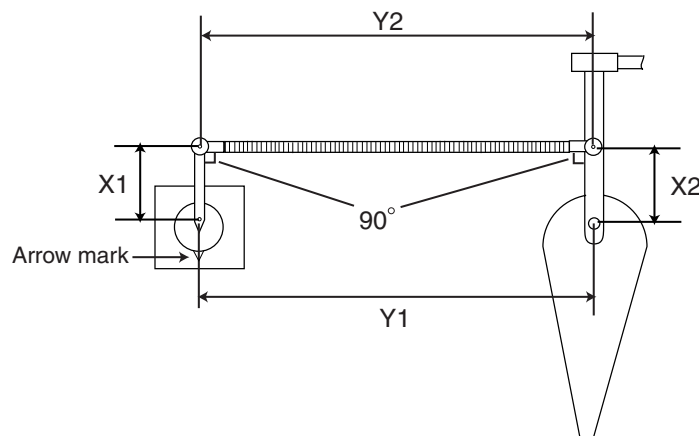
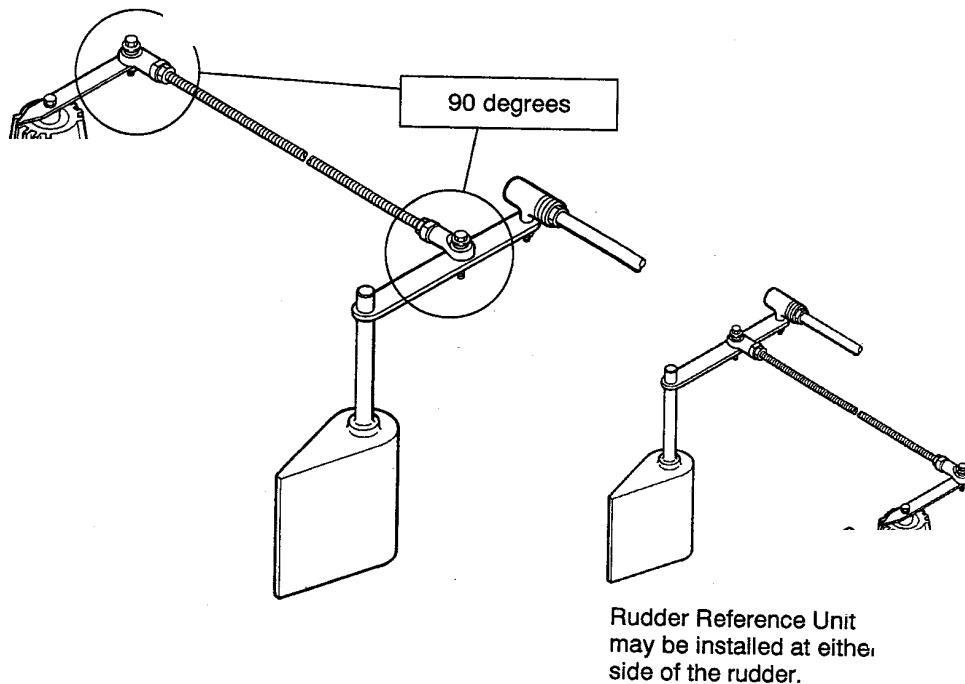

Top view

**Note 1:** The arm of rudder reference unit should be aligned with the arrow mark. Align the notch on the shaft to the arrow mark if the arm is removed.

**Note 2:** The FAP-6101 may be substituted (for FAP-300/330) instead of the FAP-6112.

## 1. INSTALLATION OF UNITS

### **Relationship between Reversing Pump Flow Rate and Steering Cylinder Capacity**

The table below shows a rough guideline to determine the proper Reversing Pump Flow Rate to match with the Hydraulic Steering Cylinder capacity. Your experience with specific boat designs may cause you to select a pump/cylinder relationship outside of the range of these guidelines.

	Hardover to Hardover is 70°.	Hardover to Hardover is 90°.
1.0 cu. in./sec. pump	5.85 to 17.5 cu. in.	7.5 to 22.5 cu. in.
1.6 cu. in./sec. pump	9.36 to 28.0 cu. in.	12.0 to 36.0 cu. in.

- If the Hydraulic Cylinder capacity is much smaller than the recommended values in the table, the rudder turning speed maybe too fast for the pilot to deliver proper performance. The rudder deadband will decrease and the Navpilot System may not apply enough voltage for the pump motor to start because the applied "Duty Cycle" will be too low.
- If the Hydraulic Cylinder capacity is much larger than the recommended values in the table, the rudder turning speed may be too slow to allow the Navpilot System to control the boat effectively.

## 1.4 Remote Controllers (option)

Two remote controllers may be connected to the processor unit FAP-5002. To connect three or four remote controllers, the optional distributor FAP-6800 is required.

**Note 1:** The distributor FAP-6800 enables connection of three NFU (Non-Follow Up) type remote controllers (button and lever) to the processor unit.

**Note 2:** Keep the remote controller out of water splash.

### **Dial type remote controller FAP-5551/5552**

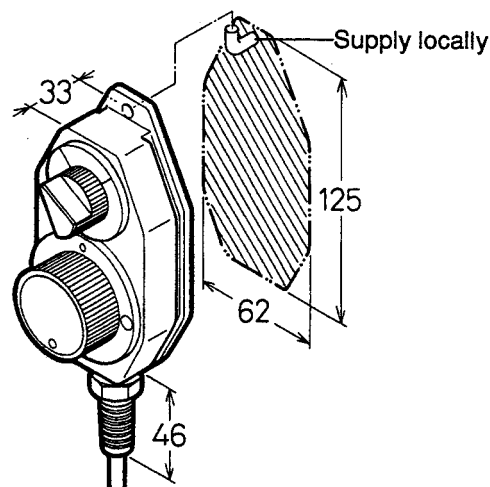

*FAP-5551, bulkhead mounting*

Dial type remote controller FAP-5551/5552 can also be mounted on the bulkhead by using the optional bracket OP64-2 (Code No.: 009-004-030).

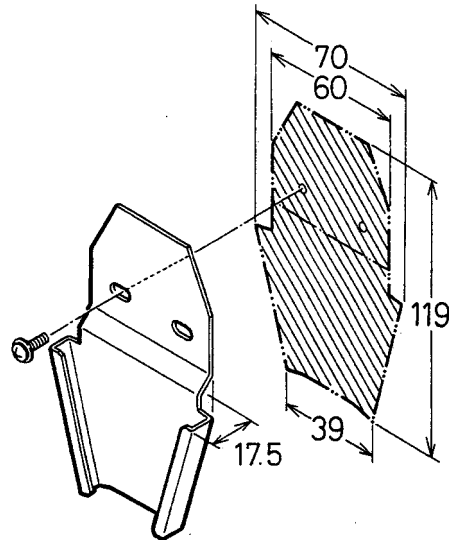

*Mounting the bracket for FAP-5551/5552*

For handheld operation in the opposite direction, reverse the switch and dial blocks so that the dial is readable. To do this, loosen the four screws shown below. Note that the switch and dial blocks are inserted into the controller body with O-rings. Be careful not to damage them.

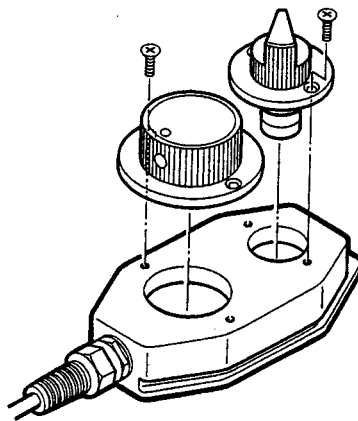

*Reversing the switch and dial blocks*

1. INSTALLATION OF UNITS

**Button type remote controller FAP-6211/6222**

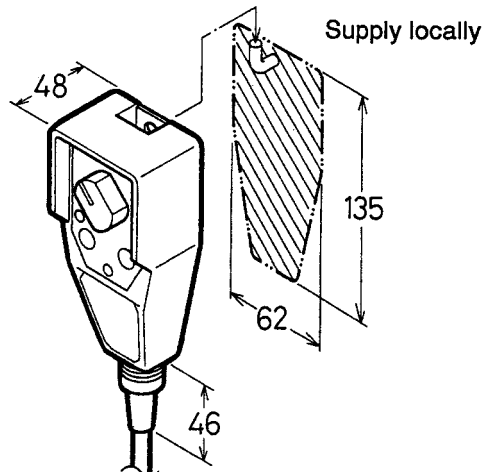

*FAP-6211, bulkhead mounting*

**Lever type remote controller FAP-6221/6222**

Allow sufficient space around the unit for maintenance.

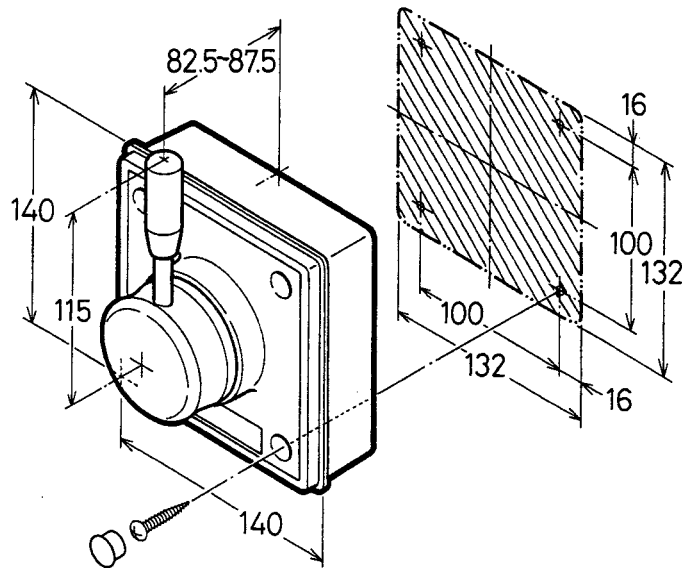

*FAP-6221, bulkhead mounting*



To mount the FAP-6221/6212 in a panel, the optional flush mount kit OP64-4 (Code No.: 009-005-790) or OP64-5 (Code No.: 009-005-800) is required.

Contents of OP64-4

Name	Type	Code No.	Qty
Panel	OP64-4	009-006-370	1
O-ring	64-015-4524	009-006-180	1
Hex. nut	M4	000-863-106	4
Flat washer	M4	000-864-256	4
Spring washer	M4	000-868-786	4

Contents of OP64-5

Name	Type	Code No.	Qty
Fixing plate	OP64-5	009-006-200	1
O-ring	64-015-4524	100-145-111	1
Hex. nut	M4	000-863-106	4
Spring washer	M4	000-864-256	4
Hex. bolt	M4x35	000-868-786	4

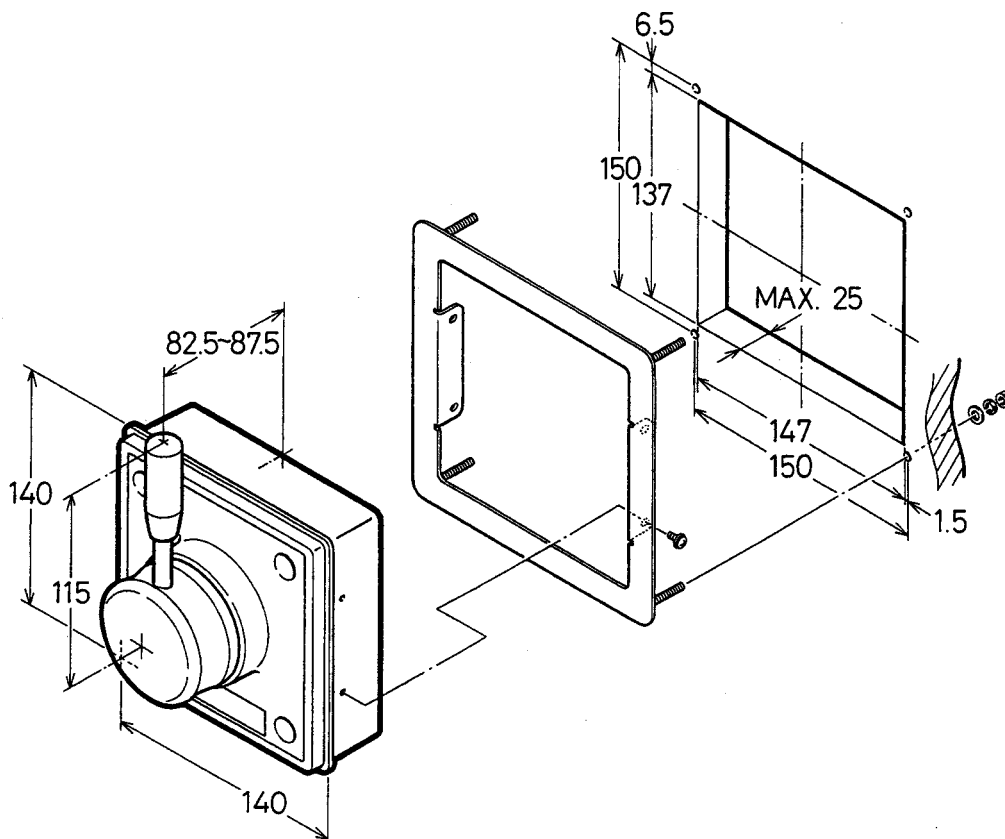

FAP-6221, flush mounting (OP64-4)

# 1. INSTALLATION OF UNITS

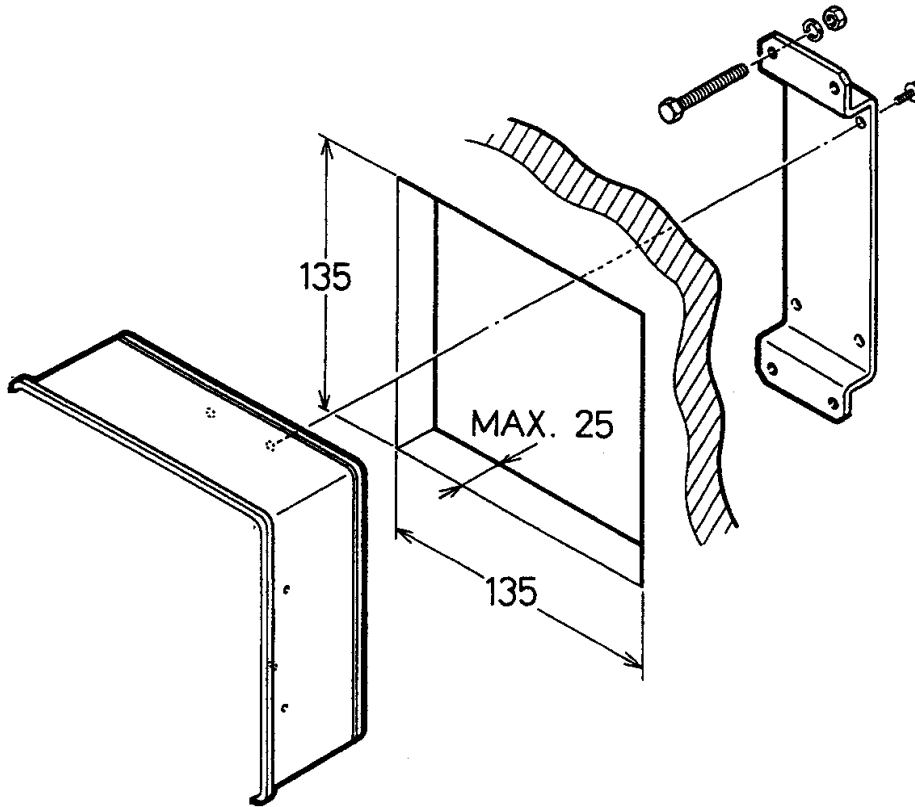

FAP-6221, flush mounting (OP64-5)

## **Distributor FAP-6800**

For thin walls, use nuts, bolts and washers (all are local supplied) instead of wood screws.

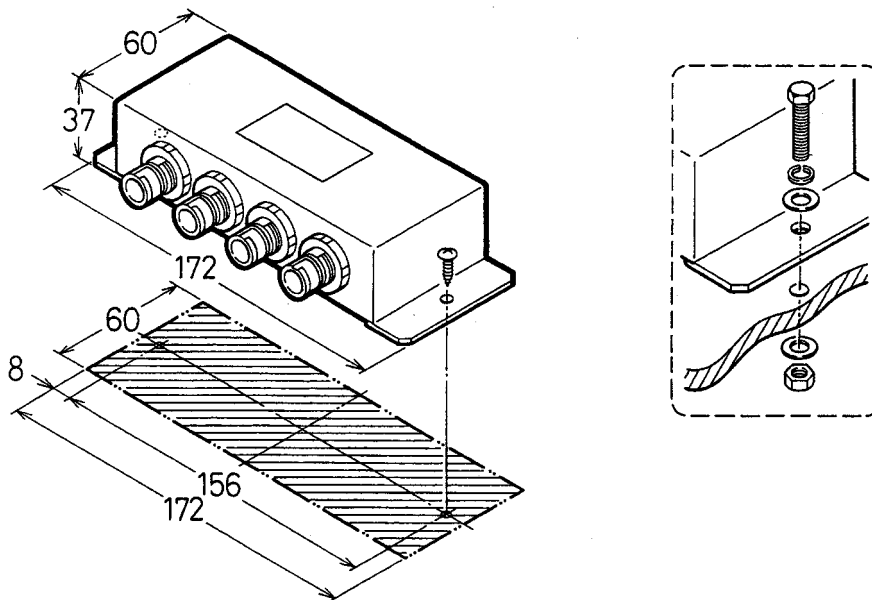

FAP-6800, desktop mounting

## 1.5 Control Unit FAP-5021

The hand-held control unit FAP-5021 can be mounted on the bulkhead or desktop using the cradle.

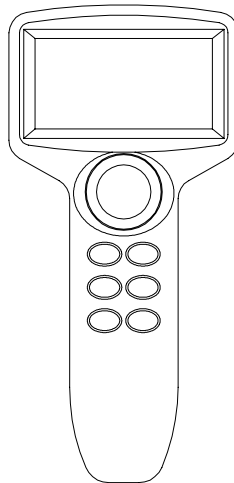

*Control unit FAP-5021*

When selecting location for the control unit, keep the following in mind.

- Mount the unit where shock and vibration are minimal.
- Do not mount the control unit under “Plexiglas” or any other type of shielding which could trap heat and moisture or magnify sunlight energy onto the surface of the display.
- A magnetic compass will be affected if the control unit is placed too close to the magnetic compass. Observe the compass safe distances to prevent disturbance to the magnetic compass. Standard: 0.3 m, Steering: 0.3 m

### 1.5.1 Mounting method

Follow the procedure below to mount the control unit.

1. Fasten four self-tapping screws (4x20, supplied) to fix the cradle.

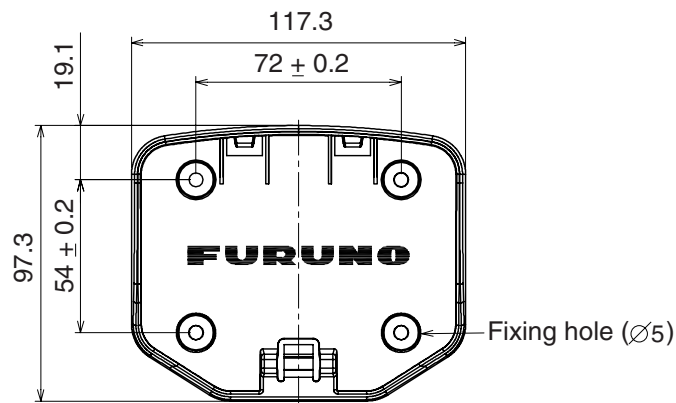

*Dimension of cradle*

2. Attach the control unit to the cradle.

## 1. INSTALLATION OF UNITS

### 1.6 Junction Box (option)

The control unit FAP-5021 has 10 m cable. When you need to extend the cable, the optional junction box is useful.

Name: Junction Box      Type: FAP-6821      Code No.: 000-090-411

Name	Type	Code No.	Qty	Remarks
Junction box	FAP-6821	000-090-412	1	w/10 m cable
Self-tapping screw	4x20	000-805-687	4	

Fix the junction box with four self-tapping screws (4x20, supplied).

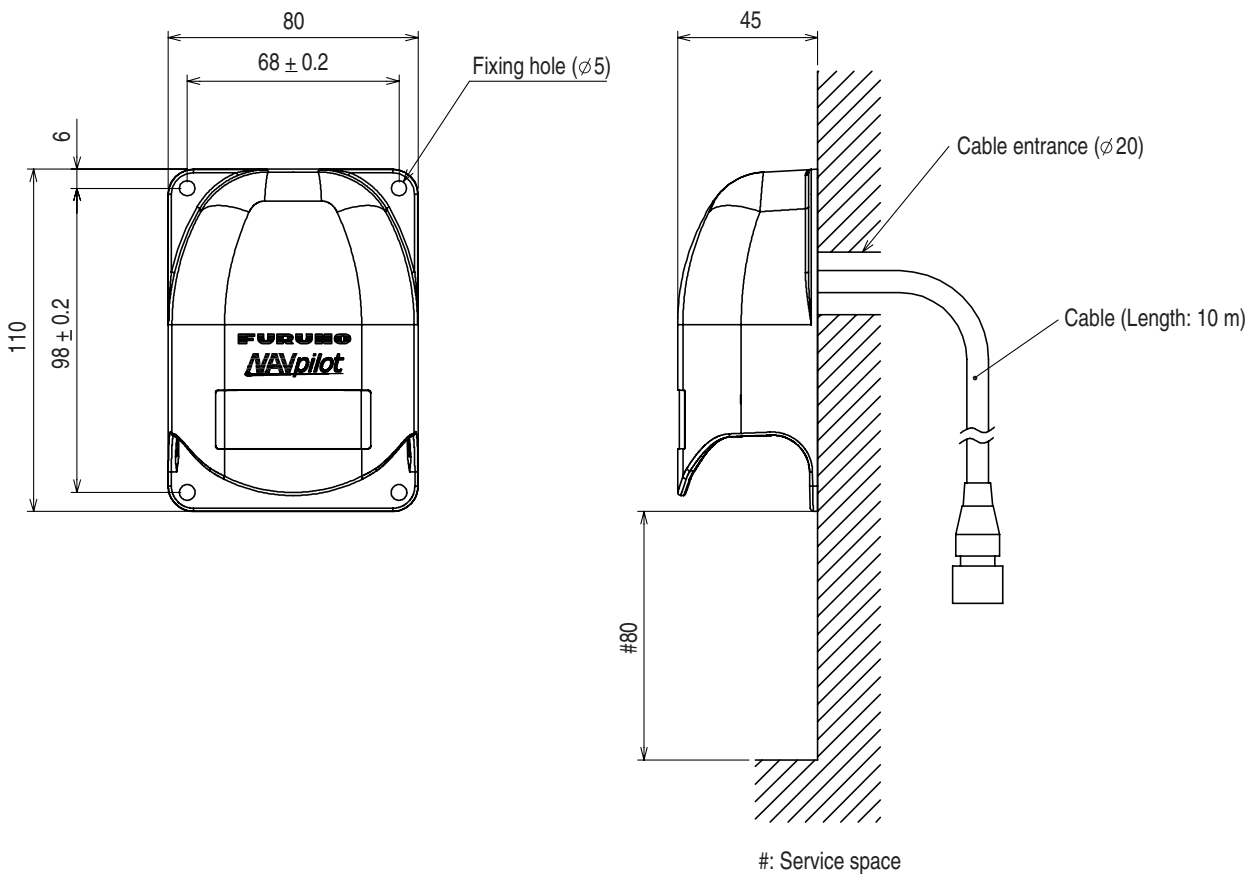

**Note:** When the control unit is not connected, attach the terminator (supplied) to the junction box.

# 2. WIRING

## 2.1 Wiring System

All units are connected to the processor unit. The cables should be separated as far as possible from cables carrying radio frequency or pulsed signals. At least one meter separation is recommended.

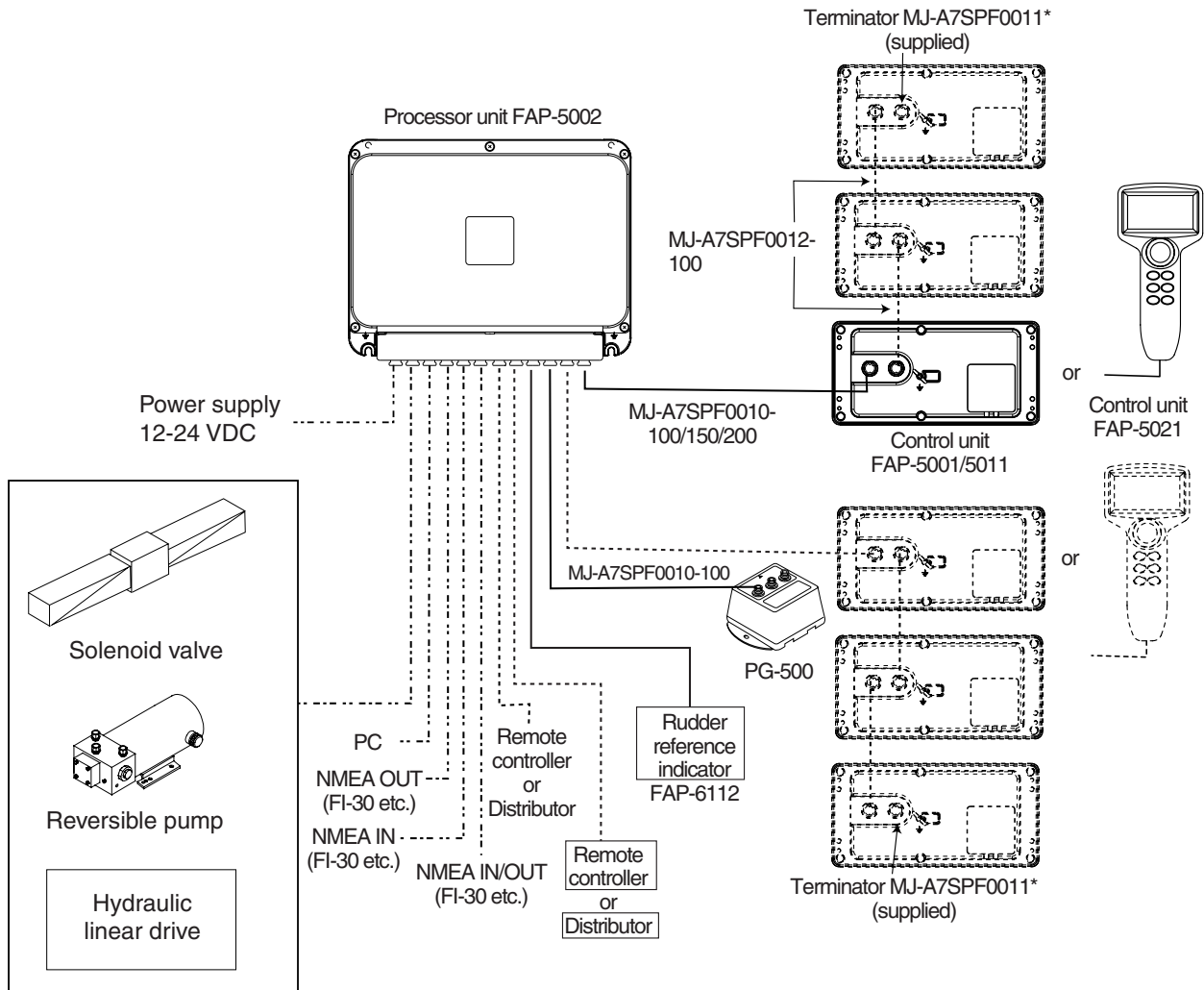

\*Attach the terminator to the empty connector of the last control unit in the series.

*Wiring*

## 2.2 Processor Unit

All cables run into the processor unit from the cable entrance and are connected to the terminal board inside.

**Note:** When connecting the FAP-5021 and FAP-6112 to the processor unit directly, cut off the connector (MJ-A7SPF) at the end of cable and then do the follows.

### 2.2.1 How to fix cables to the clamp

Cables are not location-specific so you may fix them on the cable clamp in any order.

1. Unfasten five pan head screws to remove the cover.
2. Unscrew five pan head screws to dismount the clamp stopper.

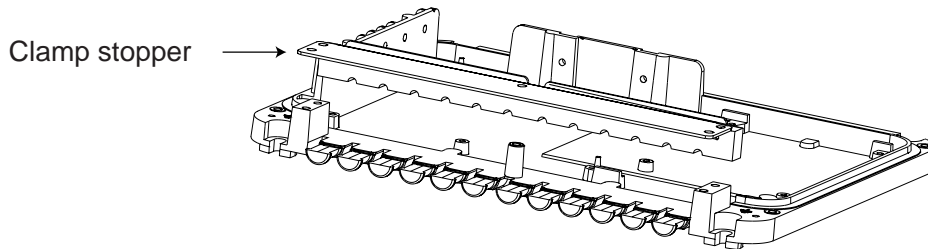

*Processor unit, clamp stopper*

3. Twist cable cores, and then insert them into the cable block as appropriate.
4. For NMEA cable, wind vinyl tape (local supply) around cable cores.
5. Fasten three cable ties to attach a cable to the appropriate leg of the processor unit as below.

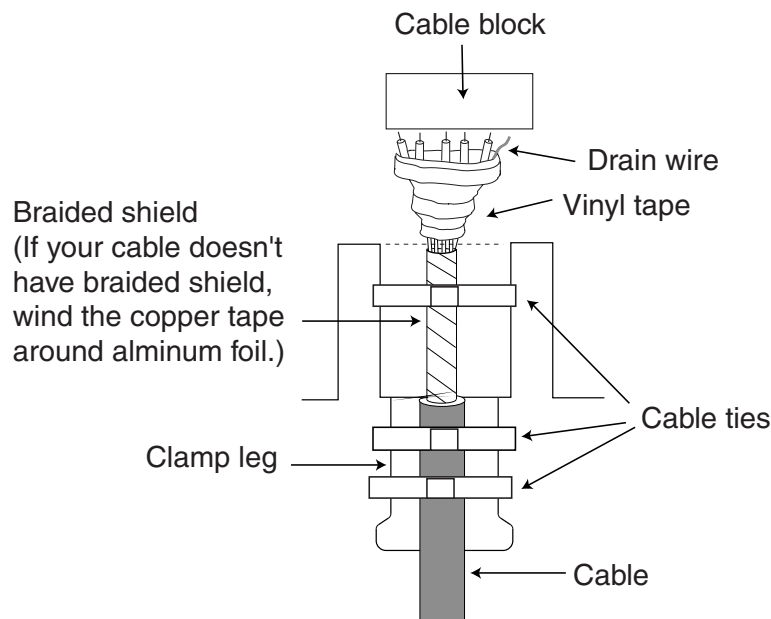

*How to fix the cable to clamp leg*

## 2.2.2 How to insert the cable into the cable blocks

Cables are terminated at the cable blocks inside the processor unit. Insert cables into the cable blocks as follows:

1. Open the processor unit.
2. Insert a slotted-head screwdriver between the upper cable block and lower cable block, and then lift screwdriver to separate the blocks.

To separate block in the back row, disconnect the block in the front row first.

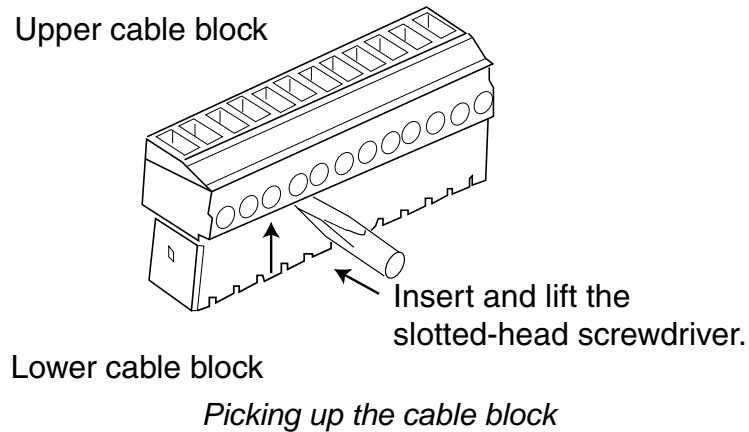

2. Using a slotted-head screwdriver having a blade of 2 mm approximately, loosen the fixing screws on the upper cable block to open the cable entrances.

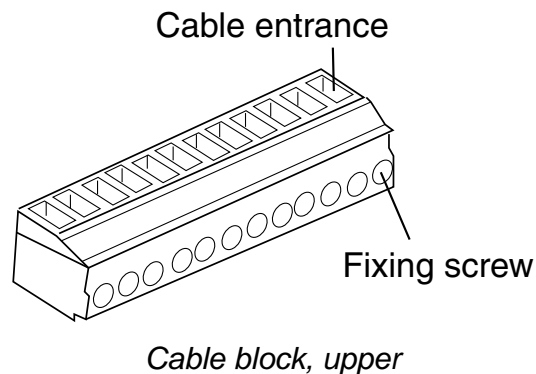

3. Insert the cable cores in appropriate entrances.
4. Fasten the fixing screws to fix the cable cores.
5. Reattach the upper cable block to the lower cable block.

**Note:** When connecting two control units to the processor unit (using TB8 and TB9 on the SPU Board 64P1140), change the position of jumper switch JP-1 from #1-2 to #3-4. For a control unit, use the TB8 and JP-1 should be at #1-2.

## 2. WIRING

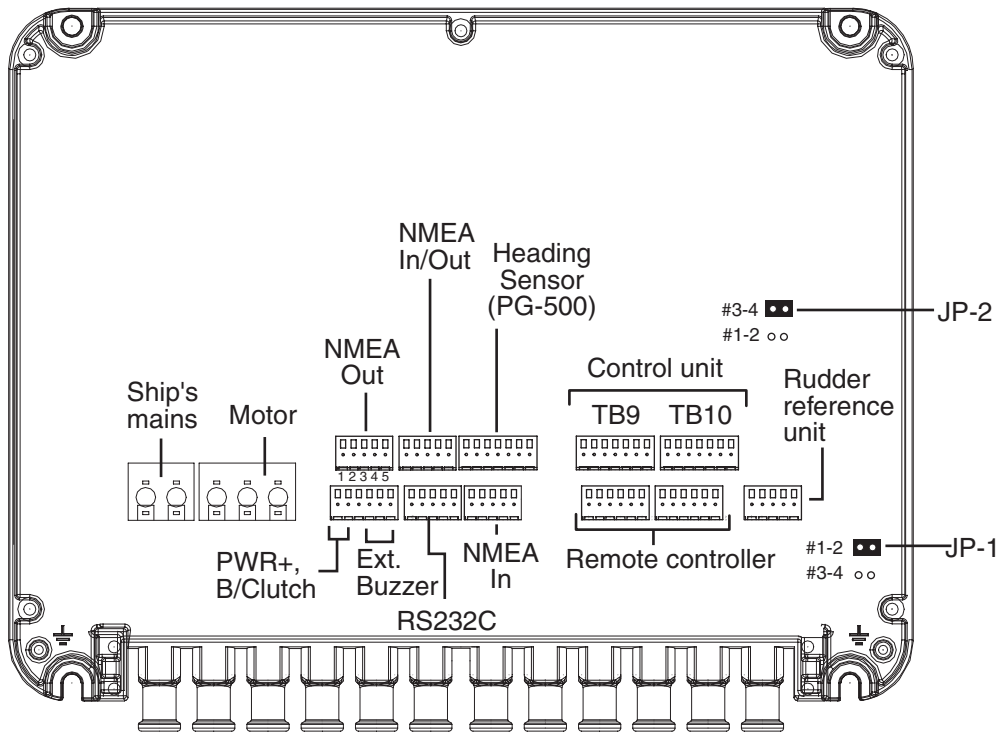

*Processor unit, inside view*

### 2.2.3 Power and Motor cable

For ship's mains cable and motor line cable, use the recommended shielded cable in the table shown below. Connect the ship's mains cable to a breaker which has a rating suitable to the motor.

Cable length	Motor Voltage			
	12 VDC		24 VDC	
	Section of core (mm <sup>2</sup> )	AWG	Section of core (mm <sup>2</sup> )	AWG
3 m or less	2.5	12	2.5	12
6 m or less	4	10	2.5	12
10 m or less	6	8	4	10
16 m or less	10	6	6	8



**Connecting a reversible pump**

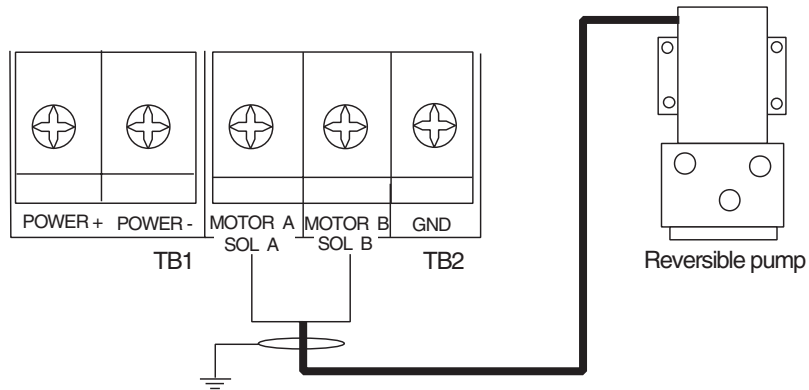

**Connecting a hydraulic linear drive**

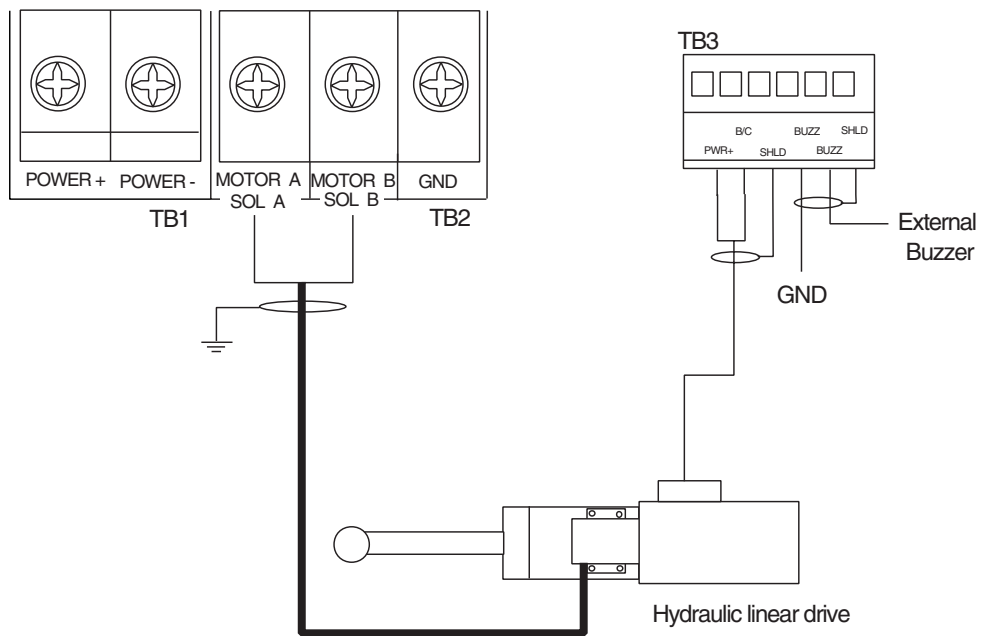

**Connecting a solenoid valve**

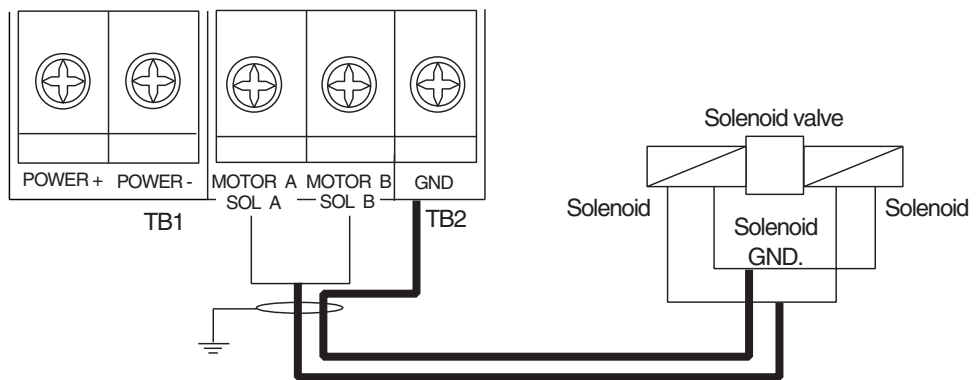

*Connecting motors*

## 2. WIRING

### 2.2.4 Connection of Teleflex<sup>®</sup> linear sensor

When connecting the Teleflex<sup>®</sup> linear sensor AR4102/AR4302 instead of the FAP-6111, do the following modification.

1. Cut the black jumper at the back of the AR4102/4302.  
**DO NOT** cut the red jumper.
2. Make the cable connection as shown below.
3. Change the position of jumper switch JP-2 from #3-4 to #1-2, referring to the illustration shown on page 2-4.
4. Set SELECT RRU to "LINEAR SENSOR" on the DOCKSIDE SETUP menu. For further details, see chapter 3.

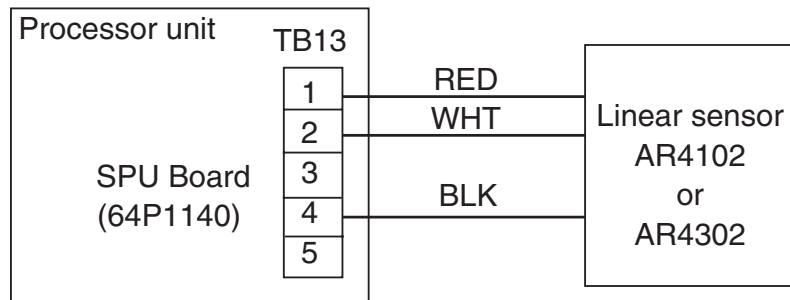

For BARE line, wind tape around where shield was removed.

*Connection of linear sensor AR4102/AR4302*

## 2.3 Control Unit

### FAP-5001/5011

A maximum of six control units may be connected. The processor unit has two ports for connection of two main control units, and two control units may be connected in series to each main control unit.

Use the cable MJ-A7SPF0010-100 (10 m, supplied), MJ-A7SPF0015 (15 m, option) or MJ-A7SPF0010-200 (20 m, option) to connect the control unit and processor unit, MJ-A7SPF0012-100 (10 m, option) to connect two control units.

### FAP-5021

A maximum two control units may be connected. Use the cable attached to the control unit (10 m) to connect to the processor unit. When extending, use the optional junction box (w/10 m cable).

**Note 1:** Ports are not location-specific so you may use them at the back of the control unit whichever.

**Note 2:** Attach the terminator MJ-A7SPF0011 to the port not used on the last control unit in the series, using an unused port.

**Note 3:** When a control unit is connected, use the TB8.

**Note 4:** Total length of cables on a series should be within 30 m.

**Note 5:** FAP-5021 can be connected at the end of FAP-5001/5011 series.

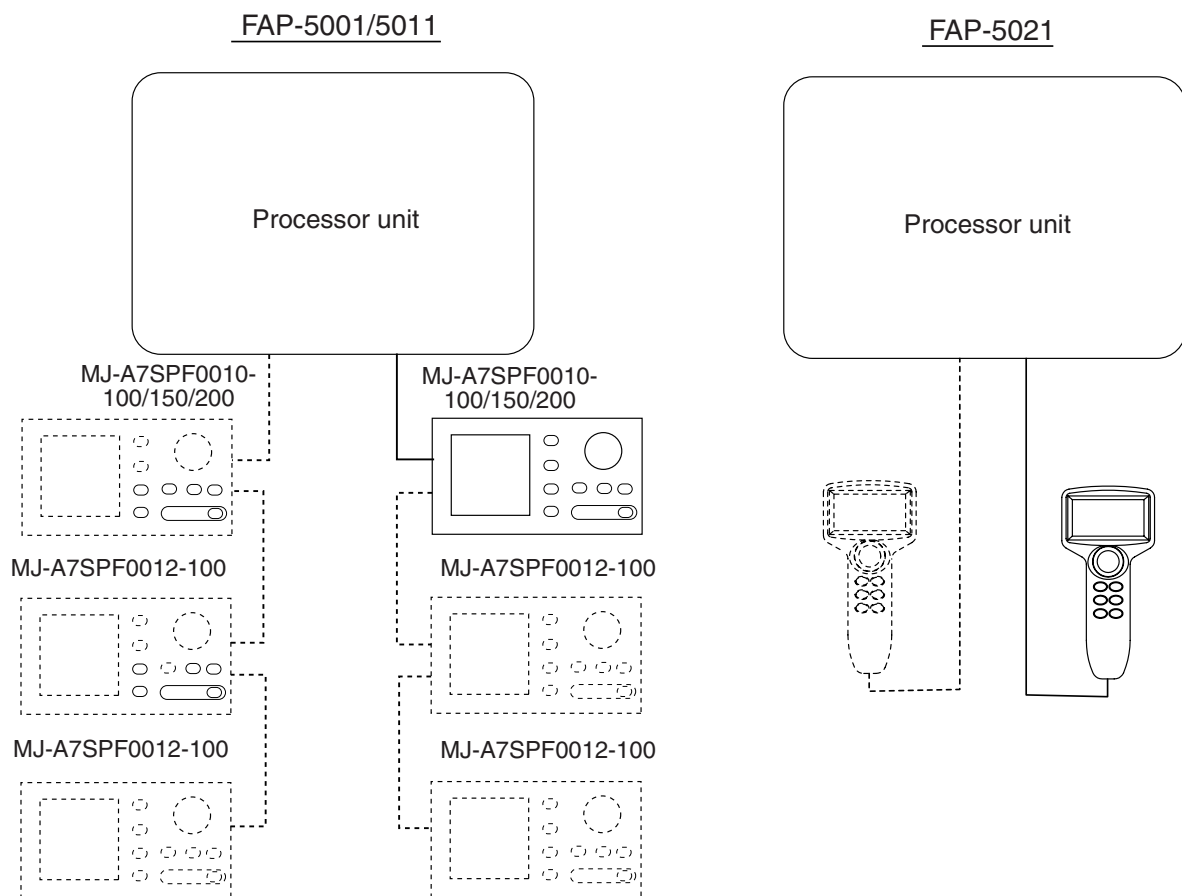

*Connection of six control units*

## 2.4 Remote Controllers (option)

The processor unit has two ports for connection of two remote controllers.

The Distributor FAP-6800 enables connection of three NFU (Non Follow-Up) type remote controllers to the processor unit.

**Note 1:** Connect remote controllers having connectors to the distributor FAP-6800.

**Note 2:** After the connection of remote controller, set the remote controller type on the SYSTEM SETUP menu. (See page 3-15.)

Remote controllers with connector	Remote controller without connector
FAP-5551 (dial), FAP-6211 (button), FAP-6221 (lever), FAP-6231 (dodge)	FAP-5552 (dial), FAP-6212 (button), FAP-6222 (lever), FAP-6232

### 2.4.1 Example remote controller connections

#### No distributor

Any two remote controllers can be connected.

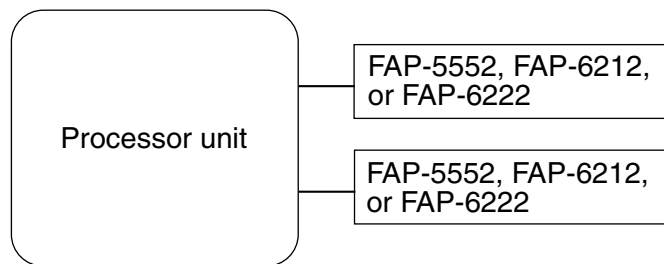

*Connection of remote controllers without distributor*

#### Dial type remote controller

For dial-type remote controller, the distributor cannot be used.

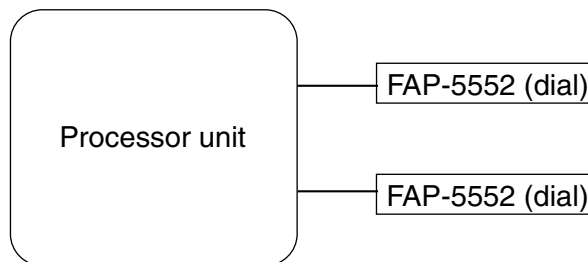

*Connection of dial type*

**Button or lever remote controller with distributor**

Maximum six button or lever remote controllers can be connected.

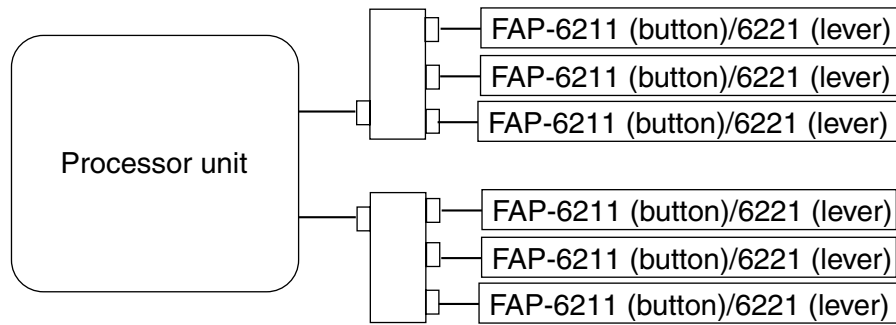

*Connection of button or lever remote controllers*

**Dodge remote controller with distributor**

Maximum six dodge type remote controllers can be connected.

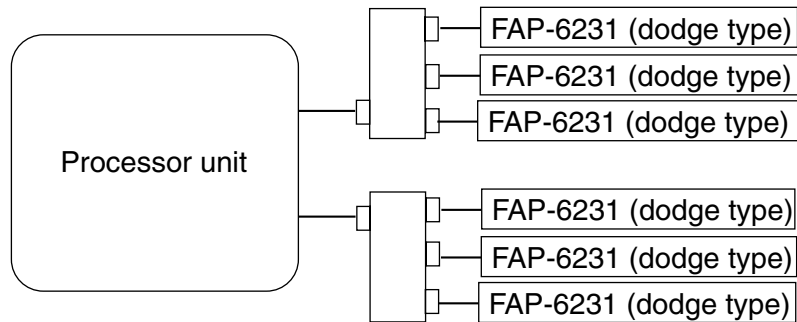

*Connection of six dodge remote controllers*

### 2.4.2 Prohibited remote controller connections

The following remote controller connections are not possible.

#### Wrong connection 1

Different types of remote controllers cannot be connected.

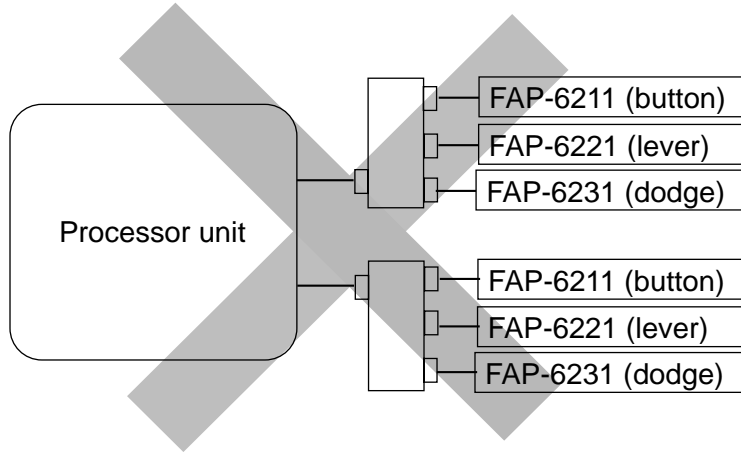

*Wrong connection 1*

#### Wrong connection 2

Only one dial remote controller can be connected.

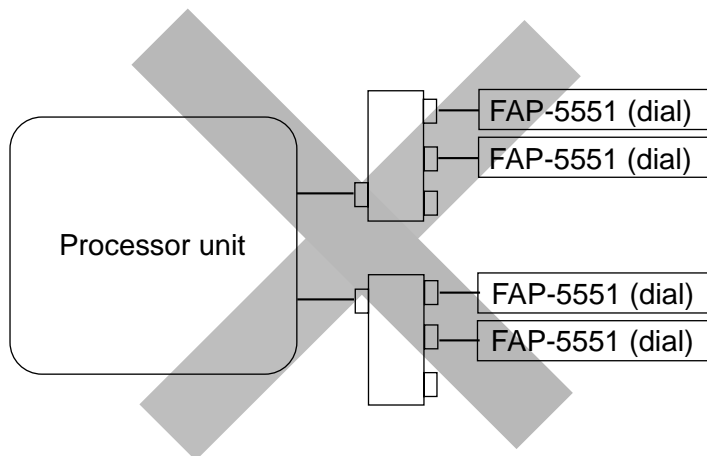

*Wrong connection 2*

**Wrong connection 3**

Multiple distributors cannot be connected.

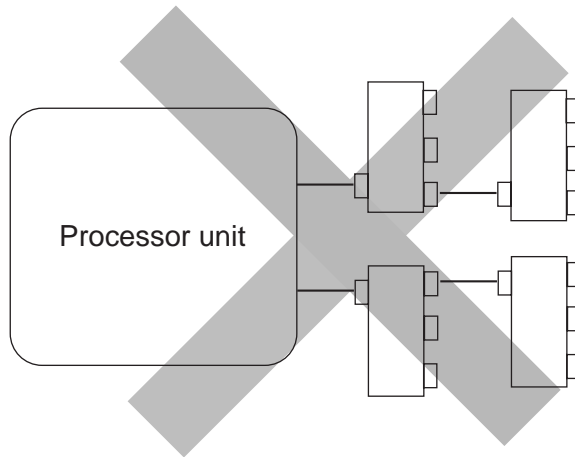

*Wrong connection 3*

**2.5 Connection of Instruments FI-30**

The FI-30 series has various sensors, such as speed, depth, wind, etc. These sensors can be connected to the NAVpilot-500/511 via the FI-30 server, and the NAVpilot-500/511 can show data from them on its graphic display. To connect the NAVpilot-500 to the FI-30 server, see the connection diagram shown below.

**Connection using the NMEA IN/OUT ports on FAP-5002**

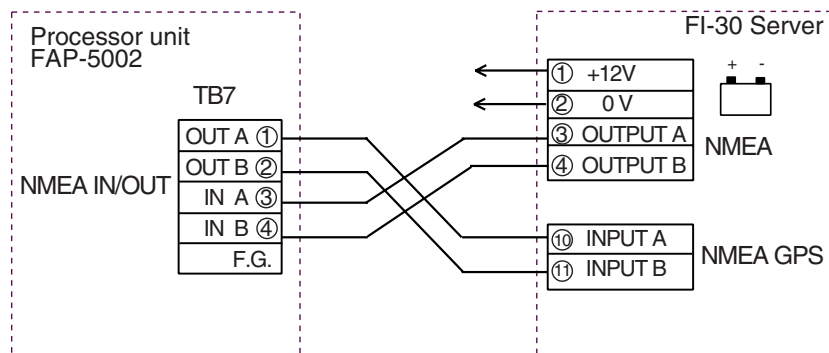

**Connection using the NMEA IN and NMEA OUT ports on FAP-5002**

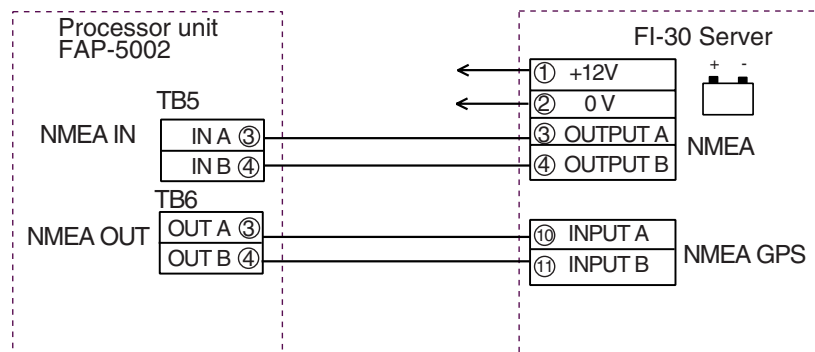

## 2.6 Input/Output Sentences

Port in the processor unit	Input/Output	Data	Sentences (priority)	Remarks	
HDG SENSOR	Input	Heading	HDT (True), HDG, HDM (Magnetic)	NMEA0183 Ver. 1.5/2.0/3.0, 200 ms interval Device talker ID (\$HE, \$HC, \$HN)	
	Output	FURUNO specified			
NMEA IN/OUT	Input/Output	Own ship position	GGA>RMC>RMA>GLL	NMEA0183 Ver. 1.5/2.0/3.0	
		Ship's speed	(SOG) VTG>RMC>RMA (STW) VHW		
		Waypoint location	RMB>WPL		
		Bearing and distance to waypoint	RMB>BWC>BWR		
		Course	RMC>RMA>VTG		
		Date	RMC>ZDA		
		Waypoint arrival alarm	AAM>RMB		
		Cross-track error	APB>XTE>RMB		
		Depth	DPT>DBT		
		Water temperature	MTW		
	Wind direction/speed	VPW>MWD>MWV			
	Output only	Auto pilot mode	FURUNO specified		
		Rudder angle			
		Bearing error			
Heading					
NMEA OUT	Output	Same as output for "NMEA IN/OUT"			
NMEA IN	Input*	Ship's speed	(SOG) VTG>RMC>RMA (STW) VHW	NMEA0183 Ver. 1.5/2.0/3.0	
		Depth	DPT>DBT		
		Water temperature	MTW		
		Own ship position	GGA>RMC>RMA>GLL		
		Wind direction/speed	VPW>MWD>MWV		
RS232C	Input*	Same as input for "NMEA IN/OUT"			
		Programs			
	Output	Outputs data same as "NMEA IN/OUT"			

\*NMEA IN and RS232C IN cannot be used at the same time.



# 3. ADJUSTMENTS

## 3.1 How to Access the Installation Menu

Set up the equipment through the installation menu. To access the installation menu, do the followings:

1. Turn the power on at the control unit.
2. Press the [STBY] ([STBY/POWER] for Navpilot-511/520) key to go to the STBY mode.
3. Press the [MENU] ([TURN/MENU] for Navpilot-511/520) key while pressing the [STBY] ([STBY/POWER]) key.
4. Release the above keys when the INSTALLATION menu appears.

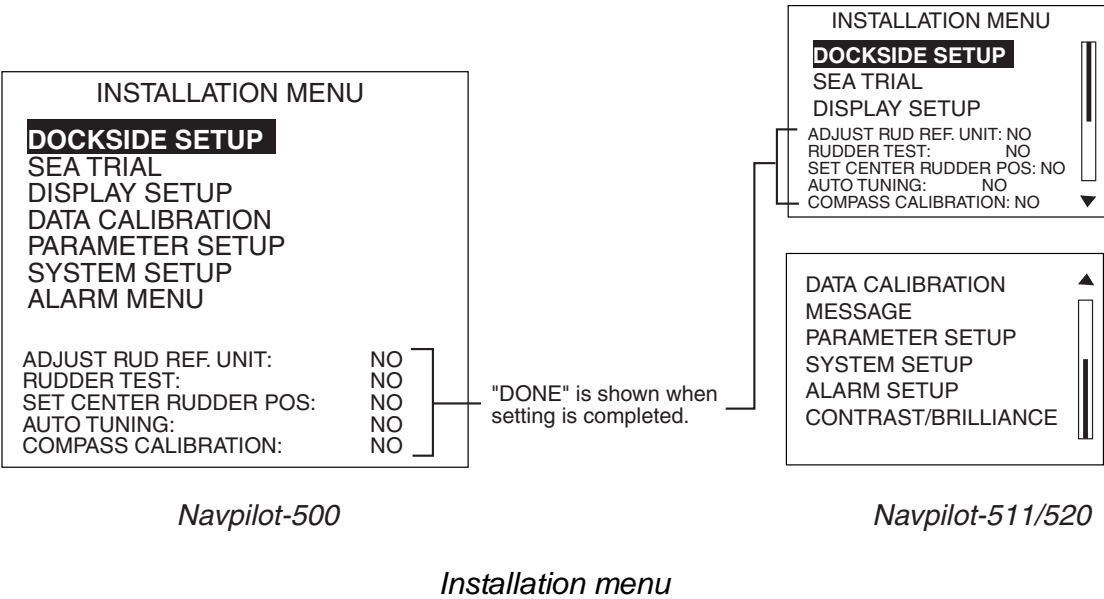

**Note:** The installation should be done in the order in which the items of the installation menu are listed.

### 3. ADJUSTMENTS

## 3.2 DOCKSIDE SETUP Menu

The DOCKSIDE SETUP menu provides for initial setup of the equipment.

1. Open the INSTALLATION menu.
2. Rotate the course control knob to select “DOCKSIDE SETUP”.
3. Press the course control knob to show the DOCKSIDE SETUP menu.

DRIVE UNIT:	<b>SOLENOID</b>
SELECT RRU:	ROTARY SENSOR
AIR BLEEDING:	?
RUDDER SENSOR ALIGNMENT	
BOAT TYPE:	PLANING
BOAT LENGTH:	
35 ft (10.7 m)	
MAXIMUM SPEED:	
30 kt (55.6 km/h)	
RUDDER LIMIT SETUP	
AUTO RUDDER LIMIT:	10°
MANUAL RUDDER LIMIT:	20°
RUDDER TEST:	?
RATE OF TURN:	3° /s
COMPASS TYPE:	PG-500
COMPASS BAUD RATE:	4800
SET CENTER RUDDER POSITION	
PUSH MENU KEY TO RETURN TO PREVIOUS MENU.	

*Navpilot-500*

DRIVE UNIT:	<b>SOLENOID</b>	
SELECT RRU:	ROTARY SENSOR	
AIR BLEEDING:	?	
RUDDER SENSOR ALIGNMENT		
BOAT TYPE:	PLANING	
BOAT LENGTH:	35 ft (10.7 m)	
MAX. SPD.:	30 kt (55.6 km/h)	
RUDDER LIMIT SETUP		
AUTO RUDDER LIMIT:	10°	

MANUAL RUDDER LIMIT:	20°	
RUDDER TEST:	?	
RATE OF TURN:	3° /s	
COMPASS TYPE:	PG-500	
COMPASS BAUD RATE:	4800	
SET CENTER RUD. POS.		
PUSH MENU KEY TO RETURN TO PREVIOUS MENU.		

*Navpilot-511/520*

*Dockside setup menu*

### 3.2.1 Selecting your drive unit

The drive type of your boat should be selected among from REVERSIBLE 24V, REVERSIBLE 12V and SOLENOID.

1. Open the DOCKSIDE SETUP menu.
2. Rotate the course control knob to select “DRIVE UNIT.”
3. Press the course control knob to show the drive unit options window.

<b>REVERSIBLE 24V</b>
REVERSIBLE 12V
SOLENOID

*Drive unit options window*

4. Rotate the course control knob to select REVERSIBLE 12V, REVERSIBLE 24V or SOLENOID depending on your boat.
5. Press the course control knob to close the window.

### 3.2.2 Selecting the type of rudder reference unit

Select the type of your rudder reference unit at here.

1. Rotate the course control knob to select "SELECT RRU", and then press the course control knob.

The select RRU options window appears.



*Select RRU options window*

2. Rotate the course control knob to select ROTARY SENSOR or LINEAR SENSOR.

ROTARY SENSOR: The rudder reference unit FAP-6111 is connected.

LINEAR SENSOR: The Teleflex® linear sensor AR4102 or AR4302 is connected.

3. Press the course control knob to close the window.

**Note:** When selecting LINEAR SENSOR, change the JP2 position certainly referring to paragraph 2.2.4.

### 3.2.3 Bleeding air in the oil cylinder

Always confirm that all of the air is bled from the steering system by moving the rudder automatically or manually.

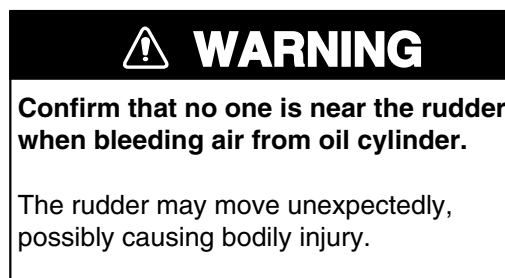

1. Rotate the course control knob to select "AIR BLEEDING", and then press the course control knob to show the air bleeding options window.

There are modes to bleed air from the system. The arrow key mode allows you to control the pump motor to bleed the system directly from the Navpilot control unit. The RRU mode allows you to turn the rudder reference arm in the lazarette or steering gear room to control the pump motor remotely.



*Air bleeding options window*

2. Rotate the course control knob to select USE ◀ ▶ KEYS or USE RRU as appropriate.
3. Press the course control knob to show the rudder indicator.

### 3. ADJUSTMENTS

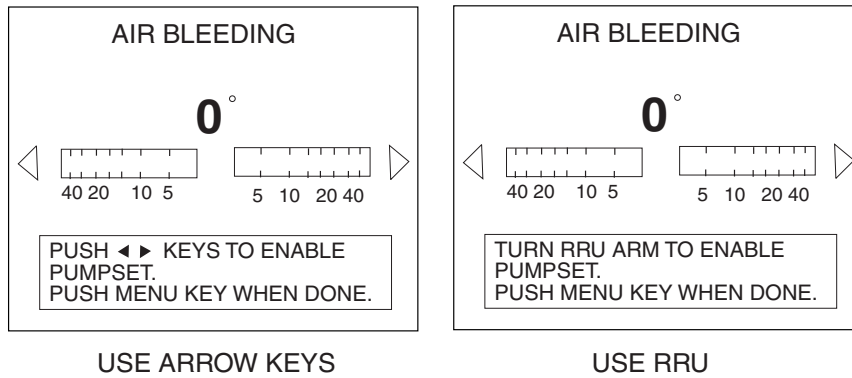

*Rudder indicators (ex. Navpilot-500)*

#### **When selecting “USE ARROW (< >) KEYS”**

- Press the [PORT] (or [STBD]) key until the indicator is completely filled (in black).
- Remove the appropriate rubber cap of the cylinder to bleed air.
- Press the [STBD] ([PORT]) key until the indicator is completely filled (in black).
- Remove the appropriate rubber cap of the cylinder to bleed air.
- Repeat steps a) through d) to bleed air completely.
- Press the [MENU] ([TURN/MENU]) key twice to finish.

#### **When selecting “USING RRU”**

- Remove the rod from the rudder reference unit slowly, and then set the arm of the rudder reference unit to 0 point (notch of the unit).
- Move the arm of the rudder reference unit to port more than 10 degrees.  
The rudder moves to port direction.
- Repeat steps a) and b) to bleed air from the oil cylinder for starboard.
- Press the [MENU] ([TURN/MENU]) key twice to finish.

After the bleeding, the indicator “?” next to “AIR BLEEDING” on the DOCKSIDE SETUP menu changes to “DONE”.

#### **3.2.4 Aligning rudder sensor**

Navpilot utilizes position sensitive of the rudder reference units and the initial physical alignment of these sensors needs to be confirmed and adjusted if necessary. Follow the below procedures to perform the initial rudder alignment.

- Center the rudder from the helm by measuring the approximate rudder center position at the rudder directly.
- Rotate the course control knob to select RUDDER SENSOR ALIGNMENT.
- Press the course control knob to show the rudder indicator.  
For Navpilot-511/520, press the course control knob twice.

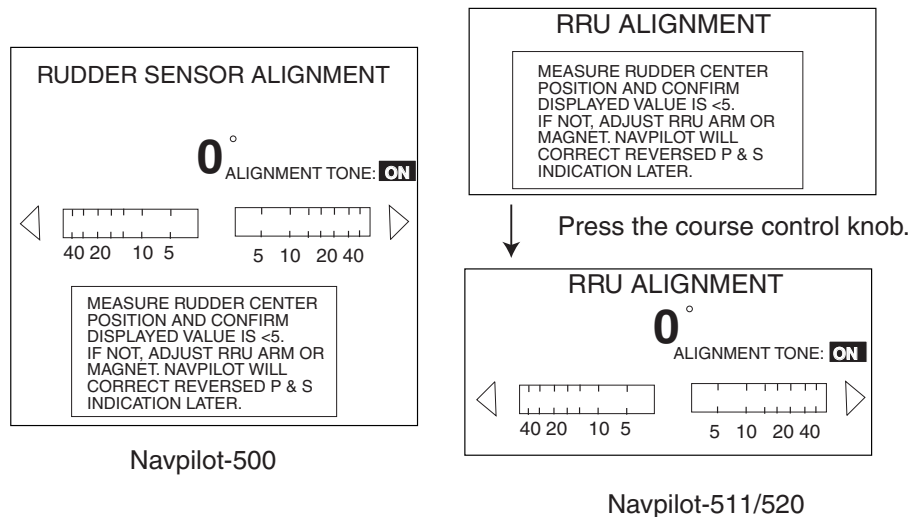

#### *Rudder sensor alignment menu*

4. With the rudder still physically centered, confirm that the displayed rudder angle indication is less than or equal to  $\pm 5^\circ$ . If not you must adjust the rudder sensor body or arm position so that the indicator is within  $\pm 5^\circ$  before continuing. If you are installing a linear sensor, move the magnet sensor so that the indicator is within  $\pm 5^\circ$  before continuing.

**Alignment Tone:** Note that there is an alignment tone that you may use to help you make this adjustment remotely, when the indicator is within  $\pm 5^\circ$ , the beep sounds continuously. If you do not need or want to hear the alignment tone, you may turn it off by pressing the course control knob and selecting "OFF" in the ALIGNMENT TONE window.

5. After you have confirmed this step and made any necessary adjustments, push the course control knob to close the window and return to the DOCKSIDE SETUP menu.

### 3.2.5 Selecting boat type

Select your boat type: PLANING, SEMI\_PLANING DISPLACEMENT or SAILBOAT depending on your boat specification. The type of boat selected affects the steering parameters and the functions available in the autopilot system.

1. Rotate the course control knob to select "BOAT TYPE".
2. Press the course control knob to show the boat type options window.



*Boat type options window*

3. Rotate the course control knob to select PLANING, SEMI\_PLANING, DISPLACEMENT or SAILBOAT as appropriate.
4. Press the course control knob to close the window.

#### 3.2.6 Entering boat length

Enter the actual boat length, between 1 and 80 feet (0.3 and 24.4 m). This length may affect the steering parameters.

1. Rotate the course control knob to select "BOAT LENGTH".
2. Press the course control knob and the current value is circumscribed with a double rectangle.
3. Rotate the course control knob to set the boat length.
4. Press the course control knob to finish.

#### 3.2.7 Entering maximum speed

Enter the maximum speed of your boat, between 1 and 99 kt (1.9 and 183.3 km/h). The speed entered affects the steering parameters.

1. Rotate the course control knob to select "MAXIMUM SPEED (MAX. SPD. For Navpilot-511/520)" from the DOCKSIDE SETUP menu.
2. Press the course control knob and the current value is circumscribed with a double rectangle.
3. Rotate the course control knob to set maximum speed.
4. Press the course control knob to finish.

#### 3.2.8 Setting port and starboard rudder limit

In this mode, you must set the maximum rudder limits or "hard-over" points for the rudder system. Once these limits are set, you also need to set the approximate center rudder position before continuing.

**Note 1:** Navpilot will AUTOMATICALLY set the port/starboard direction of the rudder angle in this step. It does not matter which way the rudder reference unit arm or linear sensor rod is installed as this correction will be done electronically.

**Note 2:** Navpilot will automatically "linearize" the rudder indication values if the rudder turns further in one direction than the other direction. Therefore, it is recommended that you make both port and starboard rudder values the same. This will avoid confusion for the customer during operation. Also, numeric value selected is not critical and need not be measured as long as you feel that your estimation is close to the proper value.

Adjust the rudder angle indication as follows.

1. Rotate the course control knob to select "RUDDER LIMIT SETUP."
2. Press the course control knob to show the RUDDER LIMIT SETUP menu.  
For Navpilot-511/520, press the course control knob twice.

RUDDER LIMIT SETUP	
PORT:	<b>10°</b>
STBD:	10
SET CENTER RUDDER POSITION	
PORT RUDDER LIMIT SETTING -TURN HELM HARD-OVER TO PORT AND SET MEASURED RUDDER ANGLE VALUE. (USUALLY 20 TO 45 DEGREES)	
PUSH MENU KEY TO RETURN TO PREVIOUS MENU.	

*Adjust RRU menu (Ex. Navpilot-500)*

3. Turn the helm to port direction completely to the hard over point.
4. Rotate the course control knob to select "PORT".
5. Press the course control knob and the "10" for PORT is circumscribed with a double rectangle.
6. Rotate the course control knob to set your boat's maximum rudder angles referring to its specifications or your best estimation.
7. Press the course control knob.
8. Turn the helm to starboard direction completely to the hard over point.
9. Rotate the course control knob to select "STBD".
10. Press the course control knob and the "10" for STBD is circumscribed with a double rectangle.
11. Rotate the course control knob to your boat's maximum rudder angles referring to the specification or your best estimation, and then press the course control knob.
12. Rotate the course control knob to select "SET CENTER RUDDER POSITION".
13. Turn the helm to the approximate rudder center or zero degree position.

**Note:** The final precise rudder center position will be set during the SEA TRIAL menu operation.

14. Press the [MENU] ([TURN/MENU]) key to close the ADJUST RRU menu.

While adjusting the rudder angle, the message "ADJUSTING RRU- PLEASE WAIT" appears on the other control units connected.

### 3.2.9 Setting rudder auto movement limit

AUTO RUDDER LIMIT determines the maximum rudder movement in degrees from the mid position in the AUTO or NAV mode.

**Note:** This setting must be less than the rudder limit values set in the previous step. It is recommended to set this value approximately 10°-15° less than the maximum rudder limit values. If necessary, this value may be increased if more rudder is required for the fishing mode.

1. Rotate the course control knob to select "AUTO RUDDER LIMIT".
2. Press the course control knob and the current value is circumscribed with a double rectangle.
3. Rotate the course control knob to set the rudder limit desired. (Setting range: 1 to 45°)
4. Press the course control knob.

### 3.2.10 Setting manual rudder movement limit

In the REM (remote) or DODGE mode, usually a wide range of rudder angles are used, and therefore a larger number should be entered. However, the setting must not exceed the rudder limit angle which is inherent to your boat. Rotate the course control knob to select “MANUAL RUDDER LIMIT”.

**Note:** This setting must be less than the rudder limit values set in the previous step. It is recommended to set this value approximately 5° less than the maximum rudder limit values.

1. Press the course control knob and the current value is circumscribed with a double rectangle.
2. Rotate the course control knob to set the rudder limit desired. (Setting range: 1 to 45°)
3. Press the course control knob.

### 3.2.11 Checking rudder status

The Rudder test checks the following, and then shows the result of the check.

- Drive type
- The presence or absence of bypass/clutch circuit
- Rudder dead band
- Rudder speed
- PWM Duty

**Note:** For power steering vessels with an engine driven power steering pump, the engines must be running and slightly above idle before this test is performed.

1. Rotate the course control knob to select “RUDDER TEST”.
2. Press the course control knob to show the rudder test options window.

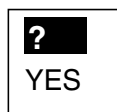

*Rudder test options window*

3. Rotate the course control knob to select “YES”.
4. Press the course control knob.  
The message “CENTER RUDDER BEFORE RUDDER TEST” appears.
5. Turn the helm to set the rudder position to 0°, and then press the course control knob.
6. Press the course control knob again to show the RUDDER SETUP AND AUTO TEST menu.  
The test starts automatically. While the test, the message “TESTIN RUDDER-PLS WAIT” appears.



RUDDER SETUP AND AUTO TEST	
DRIVE TYPE:	—
BYPASS/CLUTCH:	—
RUDDER DB :	— . — °
RUDDER SPEED:	— . — . — °/s
RUDDER DUTY:	— — %

#### *Rudder setup and auto test menu*

When the rudder test is finished, a beep sounds and the message “RUDDER TEST COMPLETED.” appears.

The results are shown on the menu.

DRIVE TYPE: REVERSIBLE or SOLENOID

BYPASS/CLUTCH: EXIST or NON

RUDDER DB: Shows the rudder dead band.

RUDDER SPEED: Rudder speed

RUDDER DUTY: PWM (Pulse Width Modulation) duty cycle for control of pump output

-For solenoid systems, this value will always be 100%.

-For reversing motor system, this value should be in a range from 50% to 90% for optimum performance.

-If the value is lower than 50%, the pump capacity is oversized for the steering cylinder volume. While the system may work well, there is a chance that the pump will fail to start (stalled pump) when there is a heavy load on the rudder system in heavy seas or large turns because the average voltage applied to the pump is too low.

-If the value is higher than 90%, the pump capacity is undersized for the steering cylinder volume. While the system may also work well, the Navpilot control unit may not be able to increase the average voltage to the pump adequately to improve the Navpilot performance in heavy or following seas.

7. Press any key to close the RUDDER TEST menu.

After the rudder test, the indication “?” next to “RUDDER TEST” on the DOCKSIDE SETUP menu changes to “DONE”.

### **3.2.12 Setting course changing speed**

Set the course changing speed (the speed in degree per second) when turning the boat in the AUTO or NAV mode.

1. Rotate the course control knob to select “RATE OF TURN” on the DOCKSIDE SETUP menu.
2. Press the course control knob and the current value is circumscribed with a double rectangle.
3. Rotate the course control knob to set the degree which you wish turn the ship in a second. (Setting range: 1 to 9°)

Set the speed according to the information below and check with the customer during the sea trial to determine if the course changing speed is comfortable.

(Small boats: 7-9°, Large boat: 5-7°, Very large boat: 4-6°)

4. Press the course control knob to finish.

### 3. ADJUSTMENTS

#### 3.2.13 Selecting compass type

Select the heading sensor connected to your NAVpilot-500/511/520.

1. Rotate the course control knob to select "COMPASS TYPE."
2. Press the course control knob to show the compass type options window.

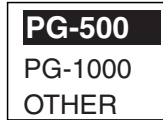

*Compass type options window*

3. Rotate the course control knob to select PG-500, PG-1000 or OTHER depending on the heading sensor connected. (Use OTHER for connection to a Furuno Satellite Compass or Gyro Compass.)

If OTHER is selected, the auto variation compensation and self check function is not available. (Use hybrid or gyro sensor only.)

4. Press the course control knob to finish.

#### 3.2.14 Setting compass baud rate

Select the baud rate of the heading sensor connected.

1. Rotate the course control knob to select "COMPASS BAUD RATE".
2. Press the course control knob to show the compass baud rate options window.

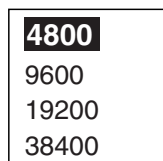

*Compass baud rate options window*

3. Rotate the course control knob to select the baud rate from among 4800, 9600, 19200 and 38400 bps.

For PG-500, select 4800 bps (default setting).

4. Press the course control knob to finish.

### 3.3 SEA TRIAL Menu

Now it is time to check if your boat can run a set heading straightly with default steering characteristics, on the open sea. This trial should be conducted in calm water where there is no boat traffic or obstructions. A sea trial can only be performed when the DOCKSIDE SETUP menu has been completed and confirmed.

1. Open the INSTALLATION menu.
2. Rotate the course control knob to select "SEA TRIAL".
3. Press the course control knob to show the SEA TRIAL menu.

COMPASS CALIBRATION\*: ?  
 MAGNETIC VARIATION:  
 AUTO  
 COMPASS OFFSET: E 7.0°  
 AUTO COMP CAL UPDATE\*\*: OFF  
 SET CENTER RUDDER POSITION  
 AUTO TUNING: ?  
 RUDDER DEAD BAND: AUTO  
COG: T 359.9° HDG: 359.9°  
 PUSH MENU KEY TO RETURN\*\*\*  
 TO PREVIOUS MENU.

\*: Appears only when selecting "PG-500" or "PG-1000" at COMPASS TYPE on the DOCKSIDE SETUP menu.

\*\* : Appears only when selecting "PG-500" at COMPASS TYPE on the DOCKSIDE SETUP menu.

\*\*\*: Heading and course are shown here when appropriate data are entered.

*Sea trial menu (Ex. Navpilot-500)*

### 3. ADJUSTMENTS

#### 3.3.1 Calibrating the heading sensor (For PG-500, PG-1000)

The COMPASS CALIBRATION activates the automatic magnetic field deviation correction for the PG-500/PG-1000 Heading Sensor.

**Note 1:** It is not necessary to perform any adjustments to locally at the PG-500 or PG-1000 Heading Sensor. Navpilot has full control of these compass sensors.

**Note 2:** This setting is available only when “PG-500” or “PG-1000” is selected at COMPASS TYPE on the DOCKSIDE SETUP menu.

1. Rotate the course control knob to select “COMPASS CALIBRATION”.
2. Press the course control knob to show the compass calibration options window.

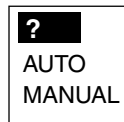

*Compass calibration options window*

3. Rotate the course control knob to select AUTO or MANUAL, and then press the course control knob.

**AUTO:** The boat turns to starboard about three or four full circles for calibration. Note that the boat will turn to starboard with the degree set at MANUAL RUDDER LIMIT on the DOCKSIDE SETUP menu (refer to the section 3.2.9.)

**MANUAL:** Use the helm to turn the boat to port or starboard for three or four full circles in a speed of about one minute/circle to perform the calibration.

4. Press the course control knob to start the calibration.

When you select AUTO at step 3, the boat starts to turn to starboard, and then the calibration starts automatically. For MANUAL, turn the boat to starboard or port in a circular course. Take about two minutes to complete the circle.

If the calibration fails, the message “CALIBRATION UNCOMPLETED, RETRY?” appears. To retry the calibration, press the course control knob.

To stop the calibration while the ship is turning, press any key to show the message “STOP CALIBRATION”. Press any key again to return to the SEA TRIAL menu.

When the calibration is successfully completed, the message “CALIBRATION COMPLETED” appears. Press any key to return to the SEA TRIAL menu.

After the calibration, the indicator “?” next to “COMPASS CALIBRATION” on the SEA TRIAL menu changes to “DONE”.

**Note:** If the boat starts to turn automatically, the COMPASS TYPE may be wrong.

### 3.3.2 Using magnetic variation

When connecting with a magnetic heading sensor (PG-500 etc.), magnetic variation information is necessary to display true heading data. In almost all cases, a GPS will be connected to the Navpilot and the GPS will send this variation information to the Navpilot automatically. Therefore, please select "AUTO". In special cases where a manual variation is required, you may input these values manually. Note that this selection only has an effect if you select "TRUE" heading indication for the Navpilot display.

Note: If TRUE heading display is selected in the DISPLAY MODE menu, the Navpilot will display true heading information even though the Navpilot may be connected to a magnetic heading sensor. If TRUE is set, the Navpilot will force the PG-500 to output true heading data in NMEA0183 and AD-10 format to any equipment connected directly. This is very valuable when connecting a Furuno radar FR-21X5 or FR-21X7 series to a Navpilot system because these radars cannot be set for a magnetic heading input and the Waypoint Lolli-pop" will only align properly when running a true heading vessel.

1. Rotate the course control knob to select "MAGNETIC VARIATION".
2. Press the course control knob to show the magnetic variation options window.



*Magnetic variation options window*

3. Rotate the course control knob to select AUTO or MANUAL.  
AUTO requires own ship's position data from the navigator connected.
4. Press the course control knob.  
When selecting MANUAL, rotate the course control knob to set the variation value, consulting a nautical chart (Setting range: W99.9° to E99.9°).
5. Press the course control knob.

### 3.3.3 Offsetting the heading data

Offset the heading data received from the heading sensor if the heading data shown on the control unit differs from the indication of the ship's compass. This offset is applied to the heading sensor data. When the control unit shows 125° though the ship's compass reading is 120°, for example, enter "5°".

1. Rotate the course control knob to select "COMPASS OFFSET".
2. Press the course control knob and the current value is circumscribed with a double rectangle.
3. Rotate the course control knob to set the offset value (Setting range: W180.0° to E180.0°).
4. Press the course control knob to finish.

### 3.3.4 Automatic distortion compensation (For PG-500)

When the magnetic field distortion changes, it can be compensated as follows.

**Note:** This setting is available only when “PG-500” is selected at COMPASS TYPE on the DOCKSIDE SETUP menu.

1. Rotate the course control knob to select “AUTO COMP CAL UPDATE”.
2. Press the course control knob to show the auto calibration options window.



*Auto calibration options window*

3. Rotate the course control knob to select “ON”.  
The AUTO LED on the PG-500 lights.
4. Press the course control knob to return to the SEA TRIAL menu.

### 3.3.5 Setting the rudder at the zero position

You must set the rudder position at zero degrees on the sea trial menu. If this setting is not completely, the boat may wander.

**Note:** Make sure that the engines are synchronized on dual engine boats when this setting is performed and maintain a normal cruising speed.

1. Rotate the course control knob to select “SET CENTER RUDDER POSITION (SET CENTER RUD. For Navpilot-511) ” from the SEA TRIAL menu.
2. Press the course control knob to show the set rudder zero options window.

FOLLOW STRAIGHT COURSE  
AND PUSH ENTER TO SET.  
ARE YOU SURE?  
YES...PUSH ENTER KNOB.  
NO...PUSH ANOTHER KEY.

*Set rudder zero options window*

3. Run the boat between 10 and 15 knot (your cruising speed).
4. When the ship runs straightly, press the course control knob to set.
5. Stop the boat, and then go to the next menu setting.

### 3.3.6 Memorizing your boat's characteristics

The automatic tuning enables the NAVpilot-500/511/520 system to automatically set up the two main steering parameters (rudder gain and counter rudder gain) for the boat. This procedure will shorten the learning time for the self-learning feature. However, if it is difficult to perform this procedure due to limited space or time constraints, this procedure is not necessary and the Navpilot will still fully learn all boat parameters over the course of the first usage. It is not mandatory to perform this procedure as in some other autopilot systems.

Do the following procedure in calm water.

1. Confirm that you have enough open water around you, and then run the boat straightly between 10 and 12 knots straight to windward.
2. Rotate the course control knob to select "AUTO TUNING" from the SEA TRIAL menu.
3. Press the course control knob to show the auto tuning options window.

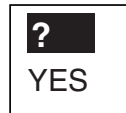

*Auto tuning options window*

4. Rotate the course control knob to select "YES".
5. Press the course control knob to start the auto tuning.  
The boat runs in the AUTO mode. While tuning, the message "AUTO TUNING – WAIT (\*\*%) appears. When the auto tuning is completed, the message "AUTO TUNING IS COMPLETED" appears. (This tuning takes approx. 5 minutes.)
6. Press any key to finish.  
After the tuning, the indicator "?" next to "AUTO TUNING" on the SEA TRIAL menu changes to "DONE".

### 3.3.7 Setting the rudder dead band

You can set the dead band of the rudder automatically or manually. The setting is normally performed automatically during the RUDDER TEST. Manually setting parameter is normally not recommended and may in fact be only useful on older vessels with chain driven or old worn rudder system.

1. Rotate the course control knob to select "RUDDER DEAD BAND" from the SEA TRIAL menu.
2. Press the course control knob to show the rudder dead band options window.



*Rudder dead band options window*

3. Rotate the course control knob to choose "AUTO" or "MAN".  
**AUTO:** Use the rudder dead band automatically detected by the RUDDER TEST on the DOCK SIDE SETUP menu.  
**MAN:** You can enter the appropriate value. (Setting range: 0.1 to 5.0°)
4. Press the course control knob to return to the SEA TRIAL menu.

### 3. ADJUSTMENTS

## 3.4 DISPLAY SETUP Menu

The DISPLAY SETUP menu allows you to choose units of measurement.

1. Open the INSTALLATION menu.
2. Rotate the course control knob to select "DISPLAY SETUP".
3. Press the course control knob to show the display setup menu.

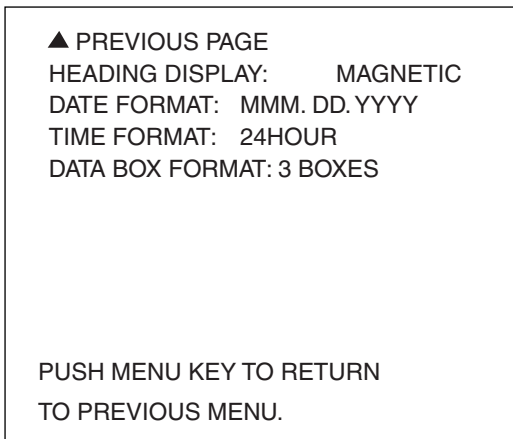
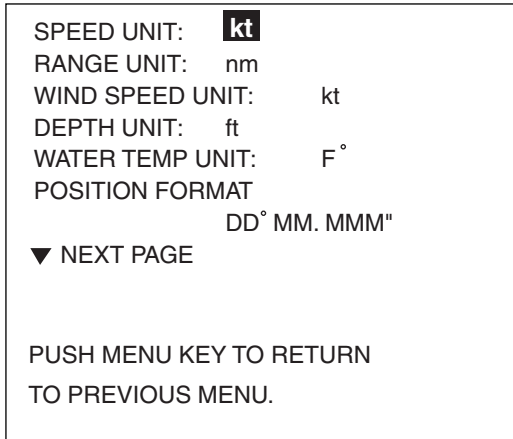

*Navpilot-500*

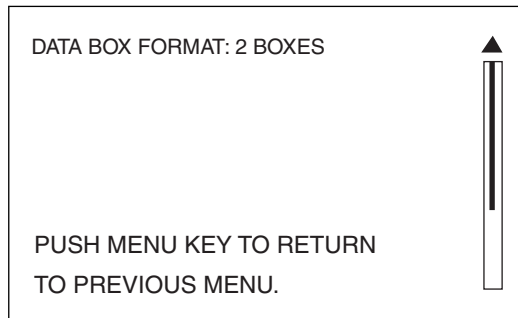
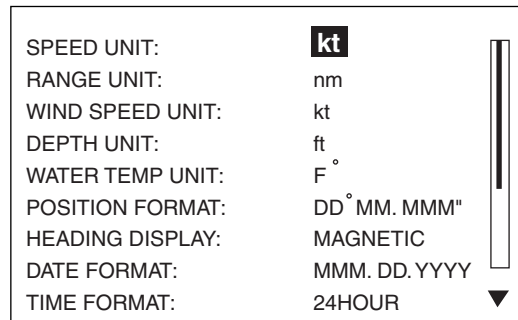

*Navpilot-511/520*

### *Display setup menu*

To change pages, select "▼NEXT PAGE" or "▲PREVIOUS PAGE" and press the course control knob.

4. Rotate the course control knob to select the item desired.
5. Press the course control knob to show the speed unit options window. The example below shows the speed unit options.

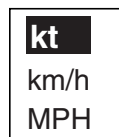

*Speed unit options window, for example*



6. Rotate the course control knob to select option. See the table shown below detailed information.
7. Press the course control knob to finish.

Item	Description	Settings
Speed Unit	Choose unit of ship's speed measurement.	kt, km/h, MPH
Range Unit	Choose unit of range measurement.	nm, km, sm, nm & yd (YARD appears in TURN menu), nm & m, km & m, sm & yd
Wind Speed Unit	Choose unit of wind speed measurement.	kt, km/h, m/s, MPH
Depth Unit	Choose unit of depth measurement.	ft, m, FA, P/B (Passi/Braza)
Water Temp Unit	Choose unit of water temperature measurement.	°F, °C
Position Format	Choose how many digits (or seconds) to display after decimal point in latitude and longitude position.	DD°MM.MM', DD°MM.MMM', DD°MM.MMMM', DD°MM' SS.S"
Next Page		
Previous PAGE		
Heading Readout	Choose heading display format.	Magnetic, True
Date Format	Choose the date display format.	DD. MMM. YYYY, YYYY. MM. DD, MMM. DD. YYYY
Time Display	Choose the time display format.	12 HOUR, 24 HOUR
Data Box Format	Choose the type of the data display.	2 BOXES, 3 BOXES (1 BOX/2 BOXES for Navpilot-511/520)

## 3.5 DATA CALIBRATION Menu

The DATA CALIBRATION menu lets you offset speed, temperature and depth data to further refine accuracy referring to the appropriate sensors.

Rotate the course control knob to select “DATA CALIBRATION” from the INSTALLATION MENU, and then press the course control knob to show the DATA CALIBRATION menu.

STW:	<b>0</b> % (7.5 kt)*
TEMP:	18.00 ° F (68.5 F)*
DEPTH:	0.0 ft (220 ft)*
WIND ANG:	-180.0° (- - - . - °) A
WIND SPEED:	-50 % (- - . - kt) A
PUSH MENU KEY TO RETURN TO PREVIOUS MENU.	

\*: Actual value input.

### *Data calibration menu*

#### 3.5.1 STW (CALIBRATION)

Offset the speed through water data.

1. Rotate the course control knob to select “STW” from the DATA CALIBRATION menu.
2. Press the course control knob and the current value is circumscribed with a double rectangle.
3. Rotate the course control knob to set offset (Setting range: -50% to +50%).
4. Press the course control knob to finish.

#### 3.5.2 TEMP (CALIBRATION)

Offset the water temperature data.

1. Rotate the course control knob to select “TEMP” from the DATA CALIBRATION menu.
2. Press the course control knob and the current value is circumscribed with a double rectangle.
3. Rotate the course control knob to set offset (Setting range: -18.00 to +18.00°F).
4. Press the course control knob to finish.

#### 3.5.3 DEPTH (CALIBRATION)

Offset the depth data.

1. Rotate the course control knob to select “DEPTH” from the DATA CALIBRATION menu.
2. Press the course control knob and the current value is circumscribed with a double rectangle.
3. Rotate the course control knob to set offset (Setting range: -30.0 to 300.0 ft).
4. Press the course control knob to finish.

### **3.5.4 WIND ANG (angle) (CALIBRATION)**

Offset the wind angle. (For sailboat only)

1. Rotate the course control knob to select "WIND ANG" from the DATA CALIBRATION menu.
2. Press the course control knob and the current value is circumscribed with a double rectangle.
3. Rotate the course control knob to set offset (Setting range: -180.0 to +180.0°).
4. Press the course control knob to finish.

### **3.5.5 WIND SPEED (CALIBRATION)**

Offset the wind speed. (For sailboat only.)

1. Rotate the course control knob to select "WIND SPEED" from the DATA CALIBRATION menu.
2. Press the course control knob and the current value is circumscribed with a double rectangle.
3. Rotate the course control knob to set offset (Setting range: -50 to +50%)
4. Press the course control knob to finish.

## 3.6 Other Settings

### 3.6.1 Setting the remote controller

When connecting the optional remote controller(s), the settings of the remote controller port and course in the FU or NFU mode are necessary.

#### Setting remote controller port

Set the type of the remote controller connected to the REMOTE1 and REMOTE 2 ports on the processor unit.

1. Open the INSTALLATION menu.
2. Rotate the course control knob to select "SYSTEM SETUP".
3. Press the course control knob to show the SYSTEM SETUP menu.

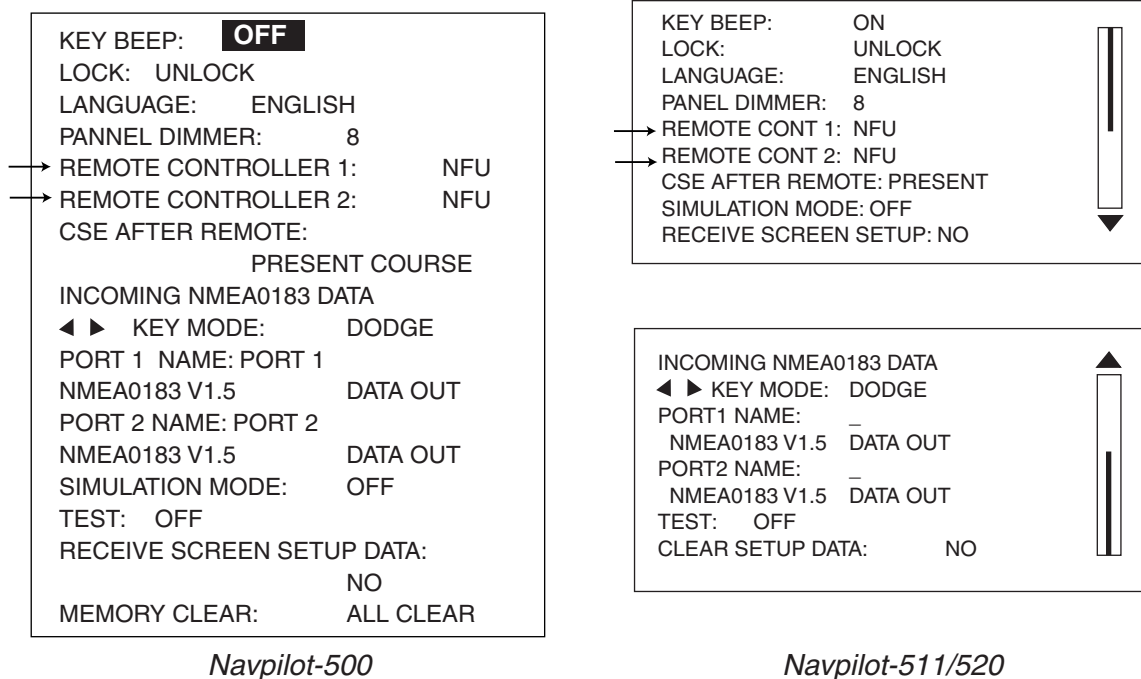

#### *System setup menu*

4. Rotate the course control knob to select "REMOTE CONTROLLER 1" or "REMOTE CONTROLLER 2" from the SYSTEM SETUP menu.
5. Press the course control knob to show the remote controller options window.



#### *Remote controller 1, 2 options window*

6. Rotate the course control knob to select the type of remote controller connected.  
 NFU: Select for button or lever remote controller connection.  
 FU: Select for dial remote controller connection.  
 DODGE: Select for dodge remote controller (FAP-6232) connection.  
 DISABLE: Disable remote controller operation.
8. Press the course control knob.

### Selecting course after the REMOTE mode is off

When the remote controller is turned off while in the AUTO mode, the “COURSE AFTER REMOTE” mode can be chosen as shown below.

1. Rotate the course control knob to select “CSE AFTER REMOTE”, and then press it to show the course after remote options window.



*Course after remote options window (Ex. Navpilot-500)*

PREVIOUS (COURSE): The previous course before using the remote controller.

PRESENT (COURSE): The heading at the moment the remote controller is turned off.

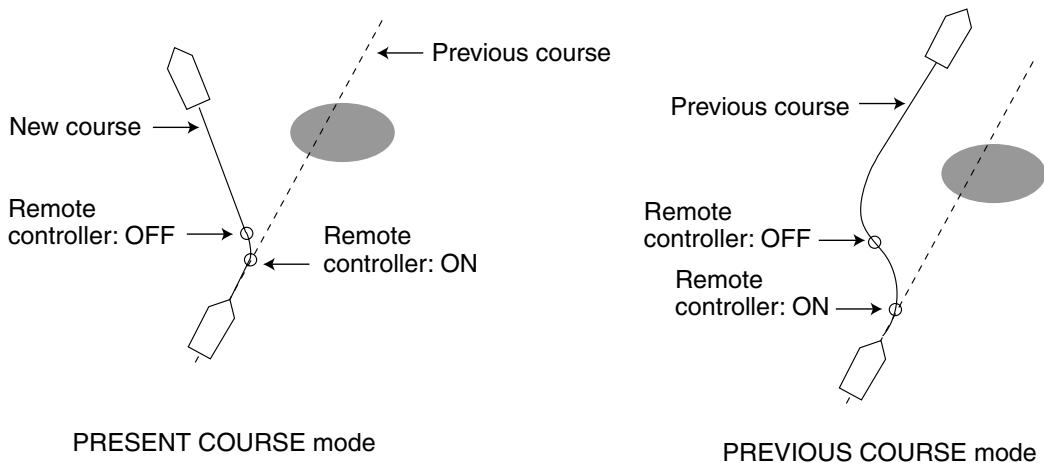

*Course after remote controller is turned off*

2. Rotate the course control knob to select PRESENT (COURSE) or PREVIOUS (COURSE) as appropriate.
3. Press the course control knob.

### Selecting the language to display

You can select the language to show on the display as follows.

1. Rotate the course control knob to select “LANGUAGE”, and then press it to show the language options window.
2. Rotate the course control knob to select a language appropriately.
3. Press the course control knob.

### 3. ADJUSTMENTS

#### 3.6.2 NMEA port setup

##### Setting the name for port

You can set the name for each port to distinguish them. This name will be used to select the navigation source.

1. Open the SYSTEM SETUP menu referring the previous paragraph.
2. Rotate the course control knob to select "PORT1 NAME" or "PORT 2 NAME."
3. Press the course control knob.
4. Use the course control knob to enter the name desired.  
To move the cursor, press the [PORT] or [STBD] key appropriately.
5. Press the [MENU] key to finish.

##### Setting the NMEA format

Set the format for the NMEA 1 IN/OUT (PORT 1) port and NMEA 2 OUT (PORT 2) port.

1. Open the SYSTEM SETUP menu referring the previous paragraph.
2. Rotate the course control knob to select the NMEA version below of "PORT 1" or "PORT 2."
3. Press the course control knob to show the options window.
4. Rotate the course control knob to select appropriate format.

Setting item	Output format	Input format
NMEA0183 V1.5	NMEA0183 Ver. 1.5	NMEA0183 Ver. 1.5, 2.0, 3.0
NMEA0183 V2.0	NMEA0183 Ver. 2.0	
NMEA0183 V3.0	NMEA0183 Ver. 3.0	
NMEA 38400BPS*	Baud rate: 38400 bps	
FI-30 FORMAT	For connection of FI-30 series	

\*: Sentences are same as NMEA V3.0.

4. Press the course control knob.

**Note:** When selecting FI-30 FORMAT, turn off the NAVpilot-500/511/520 and FI-30 at the same time always. Otherwise, data will be lost.

**Setting the sentences**

Select the sentences to output from NMEA IN/OUT (PORT 1) and NMEA OUT (PORT 2) ports.

1. Open the SYSTEM SETUP menu referring to the previous paragraph.
2. Rotate the course control knob to select "DATA OUT" of PORT 1 or PORT 2 as appropriate.
3. Press the course control knob to show the options window.  
The option window is displayed according to the setting of "PORT 1 FORMAT" ("PORT 2 FORMAT").

VER 1.5					
AAM	ON	HDM	ON	VHW	ON
BWC	OFF	HDT	OFF	VWR	ON
BWR	OFF	HSC	OFF	VWT	OFF
DBT	ON	MTW	ON	VTG	ON
GGA	OFF	RMA	ON	WPL	OFF
GLL	ON	RMB	ON	XTE	ON
GTD	ON	RMC	ON	ZDA	OFF

VER 2.0					
AAM	ON	GLC	OFF	RMC	ON
ASD	OFF	HDG	OFF	RSA	ON
BWC	OFF	HDT	OFF	VBW	OFF
BWR	OFF	HSC	OFF	VHW	ON
DBT	OFF	MTW	ON	VTG	ON
DPT	ON	MWV	ON	WPL	OFF
GGA	ON	RMA	ON	XTE	ON
GLL	ON	RMB	ON	ZDA	OFF

VER 3.0					
AAM	ON	GNS	OFF	RSA	OFF
ALR	ON	HDG	OFF	VBW	ON
BWC	OFF	HDT	OFF	VHW	ON
BWR	OFF	HSC	OFF	VTG	ON
DBT	ON	MTW	ON	WPL	OFF
DPT	ON	MWV	ON	XTE	ON
GGA	ON	RMA	ON	ZDA	OFF
GLC	OFF	RMB	ON		
GLL	ON	RMC	ON		

NMEA 38400 BPS					
AAM	OFF	GNS	OFF	RSA	OFF
ALR	OFF	HDG	OFF	VBW	OFF
BWC	OFF	HDT	OFF	VHW	OFF
BWR	OFF	HSC	OFF	VTG	OFF
DBT	OFF	MTW	OFF	WPL	OFF
DPT	OFF	MWV	OFF	XTE	OFF
GGA	OFF	RMA	OFF	ZDA	OFF
GLC	OFF	RMB	OFF		
GLL	OFF	RMC	OFF		

*Sentence selecting window*

4. Rotate the course control knob to select the sentence desired.
5. Press the course control knob to show the sentence options window.

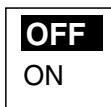

*Sentence options window*

6. Rotate the course control knob to select ON or OFF as appropriate.
7. Press the course control knob.
8. Repeat steps 4 through 7 to complete.
9. Press the [MENU] ([TURN/MENU]) key to return to the SYSTEM SETUP menu.

### 3. ADJUSTMENTS

#### Using sentences selected on other control unit

You can use the display settings selected on other control unit.

1. Open the SYSTEM SETUP menu.
2. Rotate the course control knob to select "RECEIVE SCREN SETUP NO".
3. Press the course control knob to show the optional window.
4. Rotate the course control knob to select the control unit No. from which you want to copy settings.
5. Press the course control knob.

#### Confirming the input sentences

The INCOMING NMEA0183 DATA window shows the current input sentences.

1. Open the SYSTEM SETUP menu.
2. Rotate the course control knob to select "INCOMING NMEA0183 DATA".
3. Press the course control knob to show the INCOMING NMEA0183 DATA window.

INCOMING NMEA0183 DATA						
Current input sentence →	<b>AAM</b>	BWR	GCC	HDM	RMC	VWT
	APA	DBT	GNS	MTW	VBW	WPL
	APB	DPT	GTD	MWV	VHW	XTE
	BOD	GGA	HDG	RMA	VYG	ZDA
	BWC	GLC	HDT	RMB	VWR	
PUSH MENU KEY TO RETURN TO PREVIOUS MENU.						

*Incoming NMEA0183 data window*

4. Confirm the current input sentences (in reverse video).
5. Press the [MENU] ([TURN/MENU]) key to close the window.

#### **3.6.3 Setting the function of DODGE keys**

You can select the degree which is changed when ◀ or ▶ key is pressed, among from 5, 10 or 20°.

1. Open the SYSTEM SETUP menu.
2. Rotate the course control knob to select ◀ ▶ KEY MODE.
3. Push the course control knob to select the setting among from DODGE, +/-5°, +/-10° and +/-20°.
4. Press the course control knob to set.



### 3.6.4 Clearing data

Memories can be cleared to restore default settings.

1. Open the DOCKSIDE SETUP menu.
2. Rotate the course control knob to select COMPASS TYPE, and then press the course control knob.
3. Rotate the course control knob to select "OTHER", and then press the course control knob.
4. Press the [MENU] key twice to close the INSTALLATION menu.
5. Press the [MENU] key to show the main menu.
6. Rotate the course control knob to select SYSTEM SETUP, and then press the course control knob.

KEY BEEP:	<b>OFF</b>
LOCK:	UNLOCK
LANGUAGE:	ENGLISH
PANNEL DIMMER:	1
REMOTE CONTROLLER 1:	NFU
REMOTE CONTROLLER 2:	NFU
CSE AFTER REMOTE:	PRESENT COURSE
▼ NEXT PAGE	
PUSH MENU KEY O RETURN TO PREVIOUS MENU.	

Page 1

▲ PREVIOUS PAGE	
PORT 1 FORMAT:	DATA OUT
NMEA0183 V1.5	
PORT 2 FORMAT:	DATA OUT
NMEA0183 V1.5	
SIMULATION MODE:	OFF
MEMORY CLEAR:	NO
PUSH MENU KEY O RETURN TO PREVIOUS MENU.	

Page 2

*System setup menu (through the main menu)*

7. Rotate the course control knob to select MEMORY CLEAR at the bottom of the second page, and then press the course control knob to show the option window.

<b>ALL CLEAR</b>
NAVPILOT CLR
DISPLAY CLEAR
PG-500 CLEAR

*Memory clear option window*

8. Rotate the course control knob to select "ALL CLEAR", "AUTOPILOT CLEAR", "DISPLAY CLEAR" or "PG-500 CLEAR" as appropriate and then press the course control knob.

ALL CLEAR: Clearing all data of Navpilot and PG-500 connected.

NAVPILOT CLR: Clearing all data of Navpilot.

DISPLAY CLEAR: Clearing data of the display unit of Navpilot.

PG-500 CLEAR: Clearing data of PG-500.

You are asked if you are sure to clear memory.

9. Press the course control knob to clear, or press any key to escape.

When the course control knob is pressed, the equipment restarts automatically.

### 3.6.5 Running simulation program

The simulation mode provides simulated operation to help acquaint users with the many features of the Navpilot-500/511/520. It allows you to view and control a simulated autopilot without position-fixing equipment. Most controls are operative so you may practice using the Navpilot-500/511/520. You may turn the simulation mode on or off as follows:

**WARNING**

**Do not use the SIMULATION mode on the boat.**

The rudder may move. This is special-purpose mode for technicians.

Available steering mode	AUTO, NAV, DODGE mode
Available operation	Heading, Rudder angle, Alarms, Waypoint switch, Wind data, Depth, Speed, Time

1. Open the SYSTEM SETUP menu.
2. Rotate the course control knob to select “SIMULATION MODE”.
3. Press the course control knob to show the simulation mode options window.



*Simulation mode options window*

4. Rotate the course control knob to select ON or OFF as appropriate.
5. For “ON”, enter the course value manually using the course control knob.
6. Press the course control knob.

In the simulation mode, the message “SIM” blinks on any display. Note that when turning the power of while the simulation mode is on, you will be asked at the next power-up if you want to continue the simulation mode.

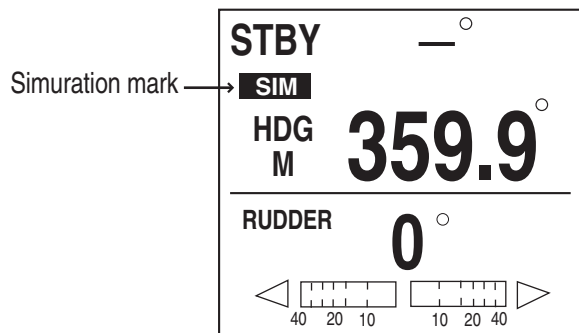

*Simulation mark (ex. STBY mode)*

# PACKING LIST NAVplot-500-E-2A

64AU-X-9858-7

1/2

NAME	OUTLINE	DESCRIPTION/CODE No.	Q'TY
<b>ユニット</b>			
<b>制御部</b>			
CONTROL UNIT		FAP-5001-E-A/B 000-090-282-00	1
制御部			
PROCESSOR UNIT		FAP-5002 000-090-283-00	1
追従発信器			
RUDDER REFERENCE UNIT		FAP-6112-200 000-090-539-00	1
<b>制御部予備品</b> PROCESSOR UNIT SPARE PARTS SP64-01401			
ヒューズ			
FUSE GLASS TUBE TYPE		FGB 125V 4A PBF 000-157-482-10	2
<b>操作部付属品</b> CONTROL UNIT SPARE PARTS FP64-01001			
コネクタ(MU) 終端器			
TERMINATOR		MU-A7SPF0011 000-147-017-00	1
<b>操作部工材</b> CONTROL UNIT INSTALLATION MATERIALS CP64-02200			
冷間圧造蝶ナット			
WING NUT		M4 SUS304 000-167-545-10	4
寸切ボルト			
THREADED ROD		M4X50 SUS304 000-162-679-10	4
ミガキ丸平座金			
FLAT WASHER		M4 SUS304 000-167-455-10	4
ハネ座金			
SPRING WASHER		M4 SUS304 000-167-405-10	4
Fマウントヨスボネジ			
FLUSH MOUNTING SPONGE		64-024-1701-0 ROHS 100-323-910-10	1

NAME	OUTLINE	DESCRIPTION/CODE No.	Q'TY
<b>制御部工材</b> PROCESSOR UNIT INSTALLATION MATERIALS CP64-02210			
ケーブル組品MJ			
CABLE ASSY.		MU-A7SPF0010-100C 000-159-681-10	1
ケーブル組品MJ			
CABLE ASSY.		MU-A7SPF0010-150C 000-159-682-10	1
コンパネツクス			
CABLE TIE		CV-150M 000-162-186-10	40
+selfタッピングネジ			
SELF-TAPPING SCREW		5X20 SUS304 000-162-608-10	4
<b>追従発信器工材</b> RUDDER REFERENCE UNIT INSTALLATION MATERIALS CP64-02601			
連結棒			
CONNECTING ROD		64-024-4606-0 100-328-060-10	1
ロッドエンドベアリング			
ROD END BEARING		REIT6 000-158-846-10	2
嵩上げスプーサ			
SPACER		64-024-4612-0 100-328-110-10	1
六角ボルト			
HEX. BOLT		M6X40 SUS304 000-158-853-10	2
ミガキ平座金			
FLAT WASHER		M6 SUS304 000-158-854-10	6
ハネ座金			
SPRING WASHER		M6 SUS304 000-158-855-10	2
六角ナット			
HEX. NUT		M6 SUS304 000-158-856-10	4

(略図の寸法は、参考値です。DIMENSIONS IN DRAWING FOR REFERENCE ONLY.)

型式/コード番号が2段の場合、下段より上段に代わる通達期品であり、どちらかが入っています。なお、品質は変わりません。  
TWO TYPES AND CODES MAY BE LISTED FOR AN ITEM. THE LOWER PRODUCT MAY BE SHIPPED IN PLACE OF THE UPPER PRODUCT. QUALITY IS THE SAME.

# PACKING LIST NAVpilot-500-E-2A

64AU-X-9858-7

2/2

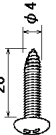
NAME	OUTLINE	DESCRIPTION/CODE No.	Q'TY
トラスタップ 1シユ SELF-TAPPING SCREW		4X20-SUS304 000-158-850-10	3

NAME	OUTLINE	DESCRIPTION/CODE No.	Q'TY
------	---------	----------------------	------

## 図書 DOCUMENT

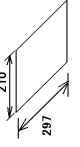
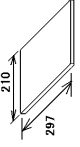
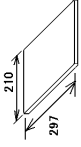
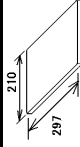
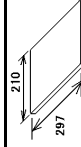
フラッシュマウント用型紙 TEMPLATE		C72-00301-* 000-146-992-1*	1
装備要領書 INSTALLATION MANUAL		114*-72500-* 000-146-988-1*	1
REFERENCE MANUAL REFERENCE MANUAL		E72-00401-* 000-151-656-1*	1
操作要領書 OPERATOR'S GUIDE		0S*-72500-* 000-146-986-1*	1
取扱説明書 OPERATOR'S MANUAL		011*-72500-* 000-146-984-1*	1

(略図の寸法は、参考値です。 DIMENSIONS IN DRAWING FOR REFERENCE ONLY.)

A-2

型式/コード番号が2段の場合、下段より上段に代わる過渡期品であり、どちらが入っています。なお、品質は変わりません。  
TWO TYPES AND CODES MAY BE LISTED FOR AN ITEM. THE LOWER PRODUCT MAY BE SHIPPED IN PLACE OF THE UPPER PRODUCT. QUALITY IS THE SAME.

C7250-Z15-H(2)

# PACKING LIST NAVplot-511-E-2A

64AW-X-9858-4 1/1

NAME	OUTLINE	DESCRIPTION/CODE No.	Q'TY
<b>ユニット</b>			
制御部 PROCESSOR UNIT		FAP-5002-11	1
追従発信器 RUDDER REFERENCE UNIT		000-090-311-00	1
操作部一式箱詰品 CONTROL UNIT COMPLETE SET		FAP-5011-E 000-090-310-00	1
<b>制御部予備品</b> SP64-01401			
ヒューズ FUSE		F0MB 125V 4A PBF 000-157-482-10	2
<b>制御部工材</b> PROCESSOR UNIT INSTALLATION MATERIALS CP64-02210			
+トラスタップソネジ 1ｼｼ SELF-TAPPING SCREW		5X20 SUS304 000-162-608-10	4
コンパックス PLASTIC BAND		CV-150N 000-162-186-10	40
ケーブル組品MJ CABLE ASSY.		MJ-A7SPF010-150C 000-159-682-10	1
<b>追従発信器工材</b> RUDDER REFERENCE UNIT INSTALLATION MATERIAL CP64-02601			
連結棒 CONNECTING ROD		64-024-4606-0 100-328-060-10	1
ロッドエンドベアリング ROD END BEARING		RB16 000-158-846-10	2
嵩上げスペーサ SPACER		64-024-4612-0 100-328-110-10	1

NAME	OUTLINE	DESCRIPTION/CODE No.	Q'TY
六角ボルト HEX. BOLT		M6X40 SUS304 000-158-853-10	2
ミカキ平座金 FLAT WASHER		M6 SUS304 000-158-854-10	6
ハネ座金 SPRING WASHER		M6 SUS304 000-158-855-10	2
六角ナット 1種 HEX. NUT		M6 SUS304 000-158-856-10	4
+トラスタップソネジ 1ｼｼ SELF-TAPPING SCREW		4X20 SUS304 000-158-850-10	3

## 図書

NAME	OUTLINE	DESCRIPTION/CODE No.	Q'TY
REFERENCE MANUAL		E72-00401-*	1
REFERENCE MANUAL		000-151-656-1*	1
装備要領書 INSTALLATION MANUAL		IM*-72500-* 000-146-988-1*	1



(略図の寸法は、参考値です。 DIMENSIONS IN DRAWING FOR REFERENCE ONLY.)

型式/コード番号が2段の場合、下段より上段に代わる通達期品であり、どちらが入っています。なお、品質は変わりません。  
TWO TYPES AND CODES MAY BE LISTED FOR AN ITEM. THE LOWER PRODUCT MAY BE SHIPPED IN PLACE OF THE UPPER PRODUCT. QUALITY IS THE SAME.

# PACKING LIST FAP-5011-J/E

64AW-X-9853-6

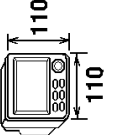
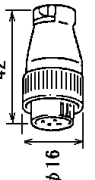
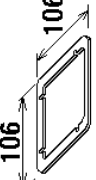
1/1

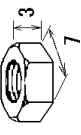
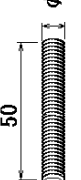
NAME	OUTLINE	DESCRIPTION/CODE No.	Q'TY
<b>ユニット UNIT</b>			
操作部 CONTROL UNIT		FAP-5011-* 000-090-442-00 **	1
<b>操作部付属品 CONTROL UNIT SPARE PARTS FP64-01001</b>			
コネクタ (MJ) 終端器 TERMINATOR		MJ-A7SPF0011 000-147-017-00	1
<b>操作部工材 CONTROL UNIT INSTALLATION MATERIALS CP64-02400</b>			
マウンティングスポンジ FLUSH MOUNTING SPONGE		64-026-1701-0 ROHS 100-323-920-10	1
ハネ座金 SPRING WASHER		M4 SUS304 000-167-405-10	4
ミガキ丸平座金 FLAT WASHER		M4 SUS304 000-167-455-10	4
六角ナット 1ｼﾝｼ HEX. NUT		M4 SUS304 000-167-488-10	4
寸切ボルト THREADED ROD		M4X50 SUS304 000-162-679-10	4

コード番号末尾の[\*\*]は、選用品の代表コードを表します。

CODE NUMBER ENDING WITH "\*\*" INDICATES THE CODE NUMBER OF REPRESENTATIVE MATERIAL.

(略図の寸法は、参考値です。DIMENSIONS IN DRAWING FOR REFERENCE ONLY.)

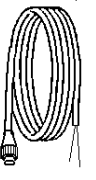
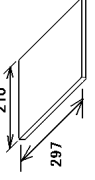
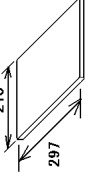
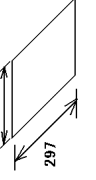
NAME	OUTLINE	DESCRIPTION/CODE No.	Q'TY
ケーブル組品MJ CABLE ASSY.		MJ-A7SPF0010-100C 000-159-681-10	1
<b>図書 DOCUMENT</b>			
操作要領書 OPERATOR'S GUIDE		OS*-72501-* 000-148-629-0* **	1
取扱説明書 OPERATOR'S MANUAL		OM*-72501-* 000-148-628-0* **	1
フロッピーマウント用型紙 TEMPLATE		C72-00302-* 000-148-674-1*	1

A-4

型式/コード番号が2段の場合、下段より上段に代わる過渡期品であり、どちらかが入っています。なお、品質は変わりません。

TWO TYPES AND CODES MAY BE LISTED FOR AN ITEM. THE LOWER PRODUCT MAY BE SHIPPED IN PLACE OF THE UPPER PRODUCT. QUALITY IS THE SAME.

C7250-Z08-G

# PACKING LIST NAVplot-520-E-2A

64AY-X-9853-7

1/1

NAME	OUTLINE	DESCRIPTION/CODE No.	Q'TY
<b>ユニット</b>			
制御部 PROCESSOR UNIT		FAP-5002-20 000-090-408-00	1
操作部一式箱詰品 CONTROL UNIT COMPLETE SET		FAP-5021-E-A 000-090-405-00	1
追従発信器 RUDDER REFERENCE UNIT		FAP-6112-200 000-090-589-00	1
<b>制御部予備品</b> SP64-01401			
ヒューズ FUSE		FGBB 125V 4A PBF 000-157-482-10	2
<b>制御部工材</b> PROCESSOR UNIT INSTALLATION MATERIALS CP64-02210			
＋トラスタップソネジ 1ｼｼ SELF-TAPPING SCREW		5X20 SUS304 000-162-608-10	4
コンパックス PLASTIC BAND		CV-150N 000-162-186-10	40
ケーブル組品MJ CABLE ASSY.		MJ-A7SPF0010-150C 000-159-682-10	1
<b>追従発信器工材</b> RUDDER REFERENCE UNIT INSTALLATION MATERIAL CP64-02601			
連結棒 CONNECTING ROD		64-024-4606-0 100-328-060-10	1
ロッドエンドベアリング ROD END BEARING		RB16 000-158-846-10	2
高上げスパーサ SPACER		64-024-4612-0 100-328-110-10	1

NAME	OUTLINE	DESCRIPTION/CODE No.	Q'TY
六角ボルト HEX. BOLT		M6X40 SUS304 000-158-853-10	2
ミカキ平座金 FLAT WASHER		M6 SUS304 000-158-854-10	6
バネ座金 SPRING WASHER		M6 SUS304 000-158-855-10	2
六角ナット 1種 HEX. NUT		M6 SUS304 000-158-856-10	4
＋トラスタップソネジ 1ｼｼ SELF-TAPPING SCREW		4X20 SUS304 000-158-850-10	3

## 図書

REFERENCE MANUAL	DOCUMENT	DESCRIPTION/CODE No.	Q'TY
REFERENCE MANUAL		E72-00401-*	1
装備要領書 INSTALLATION MANUAL		000-151-656-1* 1M*-72500-* 000-146-988-1*	1

(略図の寸法は、参考値です。 DIMENSIONS IN DRAWING FOR REFERENCE ONLY.)



型式/コード番号が2段階の場合、下段より上段に代わる過渡期品であり、どちらが入っています。なお、品質は変わりません。  
TWO TYPES AND CODES MAY BE LISTED FOR AN ITEM. THE LOWER PRODUCT MAY BE SHIPPED IN PLACE OF THE UPPER PRODUCT. QUALITY IS THE SAME.

# PACKING LIST

FAP-5021-E-A/FAP-5021-E-B

64AY-X-9851 -0 1/1

A-7

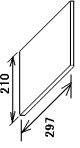
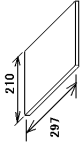
NAME	OUTLINE	DESCRIPTION/CODE No.	QTY
<b>ユニット</b>			
操作部 CONTROL UNIT	110 	FAP-5021-E-A/B	1
<b>付属品</b>			
<b>ACCESSORIES</b>			
付属品 ACCESSORIES		FP64-01201 009-000-890	1
<b>図書</b>			
<b>DOCUMENT</b>			
操作要領書 OPERATOR'S GUIDE		OSE-72501-* 000-148-604	1
取扱説明書 OPERATOR'S MANUAL		OME-72501-* 000-148-603	1

コード番号末尾の「[\*]」は、選択品の代表コードを表します。  
CODE NUMBER ENDING WITH ".\*" INDICATES THE CODE NUMBER OF REPRESENTATIVE MATERIAL.

(略図の寸法は、参考値です。 DIMENSIONS IN DRAWING FOR REFERENCE ONLY.)

C7259-Z01-A

# FURUNO

## 付属品表

### ACCESSORIES

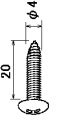
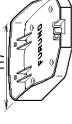
番号 NO.	名称 NAME	略図 OUTLINE	型名/規格 DESCRIPTIONS	数量 QTY	用途/備考 REMARKS
1	「+」付ネジ SELF-TAPPING SCREW		4X20 SUS304 CODE NO. 000-158-850-10	4	
2	カゴ CRADLE		64-027-1009-1 ROHS 64-027-1009-1 CODE NO. 100-327-871-10 100-327-871-00	1	

型式/コード番号が2版の場合、下段より上段に代わる蓋蓋糊品であり、どちらかが入っています。なお、品質は変わりません。  
TWO TYPES AND CODES MAY BE LISTED FOR AN ITEM. THE LOWER PRODUCT MAY BE SHIPPED IN PLACE OF THE UPPER PRODUCT. QUALITY IS THE SAME.

(略図の寸法は、参考値です。 DIMENSIONS IN DRAWING FOR REFERENCE ONLY.)

FURUNO ELECTRIC CO., LTD. C7259-F01-D



寸法区分 (mm) DIMENSION	公差 (mm) TOLERANCE
L ≤ 50	± 1.5
50 < L ≤ 100	± 2.5
100 < L ≤ 500	± 3

表 1 TABLE 1

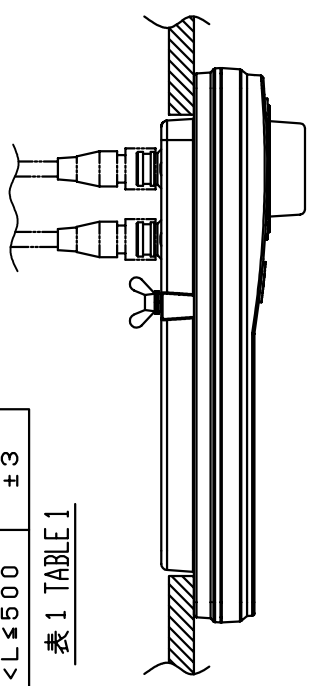

取付ネジ部断面 尺度 1/2  
DETAIL FOR FIXING (SCALE: 1/2)

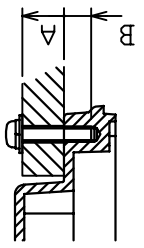

取付穴  
4-φ4.5  
FIXING HOLES

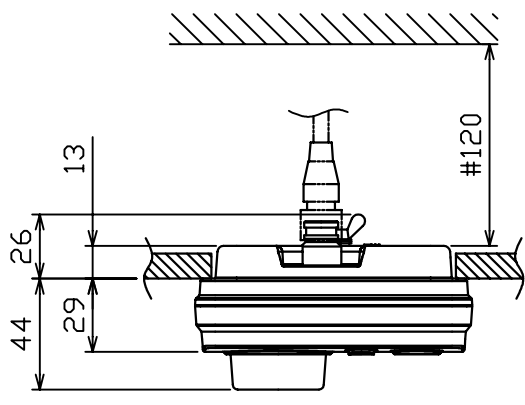

切抜穴寸法  
CUTOUT DIMENSIONS

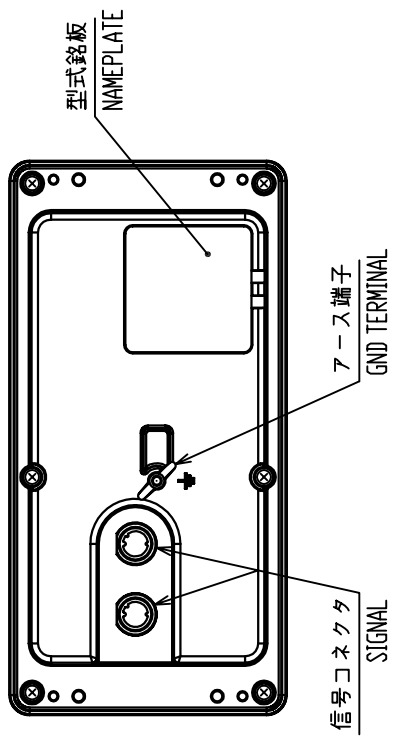
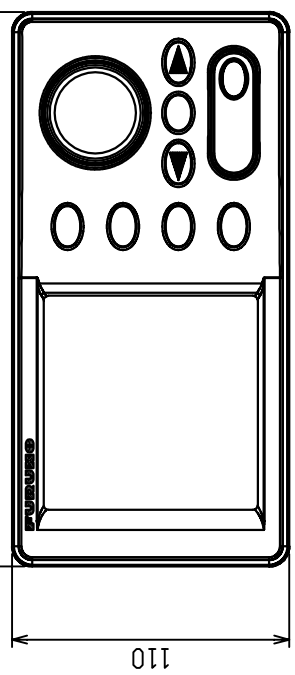
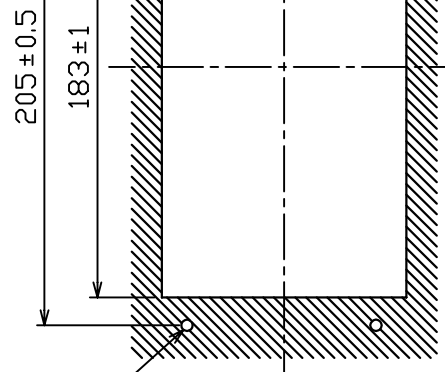

- 注 記 1) 指定外の寸法公差は表 1 による。  
 2) # 印寸法は最小サービス空間寸法とする。  
 3) 取付用ネジは、セムスネジ B M4 × 2.0 を使用のこと。  
 壁の厚さ(A)は 11 ≤ A ≤ 14 とする。それ以外の壁に装備  
 する場合、使用するネジ長さは (A + 7.8) ± 2 とする。  
 筐体にはネジ部を 8 mm 以上入れないこと。(B < 8)

- NOTE 1. TABLE 1 INDICATES TOLERANCE OF DIMENSIONS.  
 2. # RECOMMENDED SERVICE CLEARANCE.  
 3. USE SEMS SCREWS M4x2.0 FOR FIXING THE UNIT.  
 THICKNESS A: 11A14 OR SCREW LENGTH: (A+7.3)±1.5.  
 DO NOT FASTEN SCREWS INTO UNIT MORE THAN 8 mm. (B<8)

DRAWN	Mar. 20 '03	T. YAMASAKI	TITLE	FAP-5001
CHECKED	Mar. 20 '03	Y. KIMURA	名称	操作部 (埋込装備)
APPROVED	Mar. 20 '03	Y. Kamezono	外寸図	外寸図
SCALE	1/3	WKS	NAME	CONTROL UNIT (FLUSH MOUNT)
DATE			FIG. No.	64-024-100G-1
				OUTLINE DRAWING

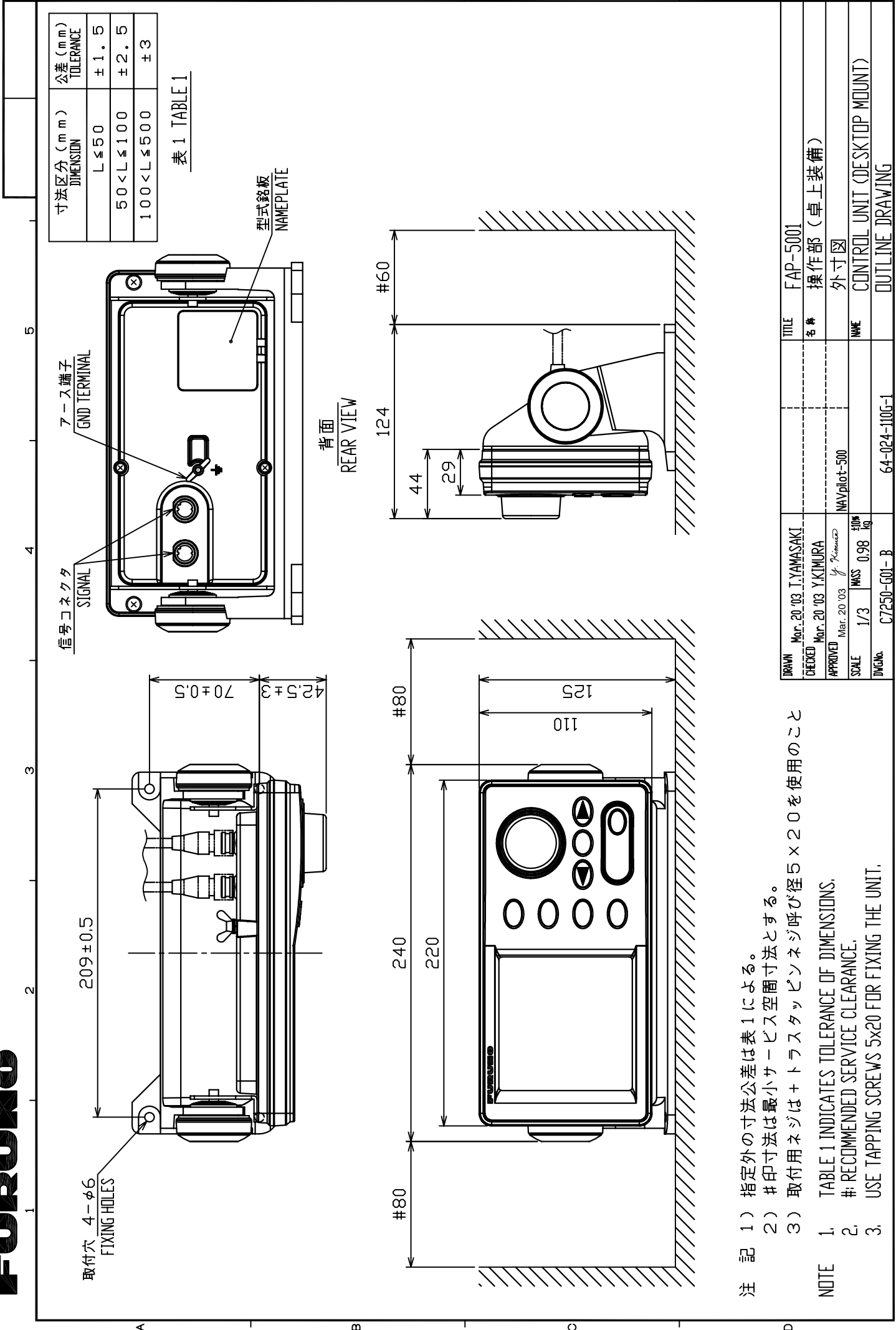

注 記 1) 指定外の寸法公差は表 1 による。  
 2) # 印寸法は最小サービスマン間寸法とする。  
 3) 取付用ネジは + トラスタッピング呼び径 5 × 20 を使用のこと

NOTE 1. TABLE 1 INDICATES TOLERANCE OF DIMENSIONS.  
 2. # RECOMMENDED SERVICE CLEARANCE.  
 3. USE TAPPING SCREWS 5x20 FOR FIXING THE UNIT.

DRAWN	Mar. 20 '03	T. YAMASAKI	TITLE	FAP-5001
CHECKED	Mar. 20 '03	Y. KIMURA	名称	操作部 (卓上装備)
APPROVED	Mar. 20 '03	Y. Kimura	外寸図	
SCALE	1/3	MASS 0.98 kg	NAME	CONTROL UNIT (DESKTOP MOUNT)
DWG. No.	C7250-001-B		OUTLINE DRAWING	

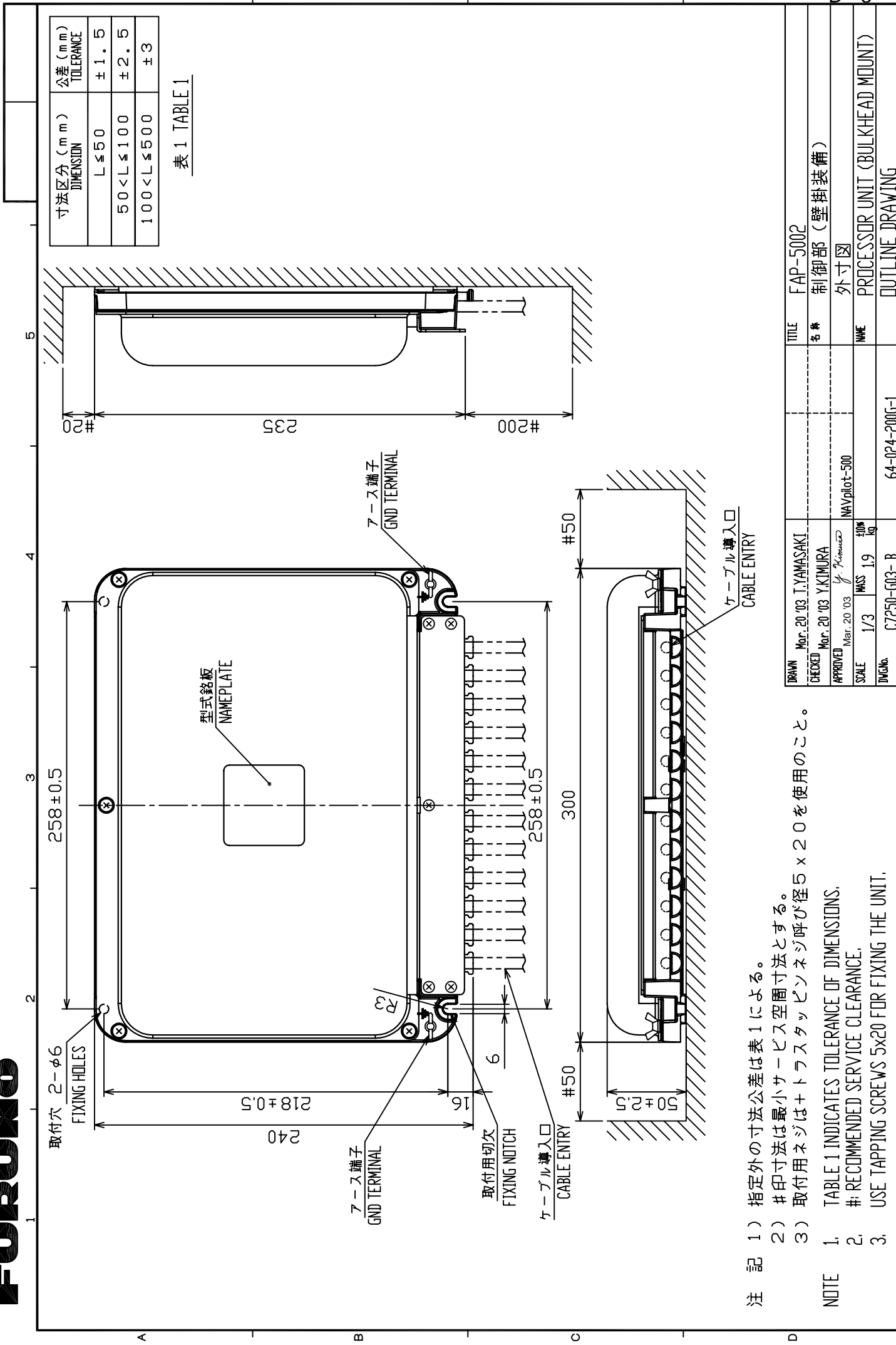

- 注記
- 1) 指定外の寸法公差は表 1 による。
  - 2) # 印寸法は最小サービスペース寸法とする。
  - 3) 取付用ネジは+トラスタップピンネジ呼び径 5 × 2.0 を使用のこと。
- NOTE
1. TABLE 1 INDICATES TOLERANCE OF DIMENSIONS.
  2. # RECOMMENDED SERVICE CLEARANCE.
  3. USE TAPPING SCREWS 5x2.0 FOR FIXING THE UNIT.

DRAWN	Mar. 20 '03	T. YAMASAKI	TITLE	FAP-5002
CHECKED	Mar. 20 '03	Y. KIMURA	名称	制御部 (壁掛装備)
APPROVED	Mar. 20 '03	Y. KIMURA	外寸図	
SCALE	1/3	WASS 1.9 kg	NAME	PROCESSOR UNIT (BULKHEAD MOUNT)
DWG. No.	C7250-G03-B			OUTLINE DRAWING
				64-024-200G-1

表 1 TABLE 1

寸法区分 (mm) DIMENSIONS	公差 (mm) TOLERANCE
$L \leq 50$	$\pm 1.5$
$50 < L \leq 100$	$\pm 2.5$
$100 < L \leq 500$	$\pm 3$

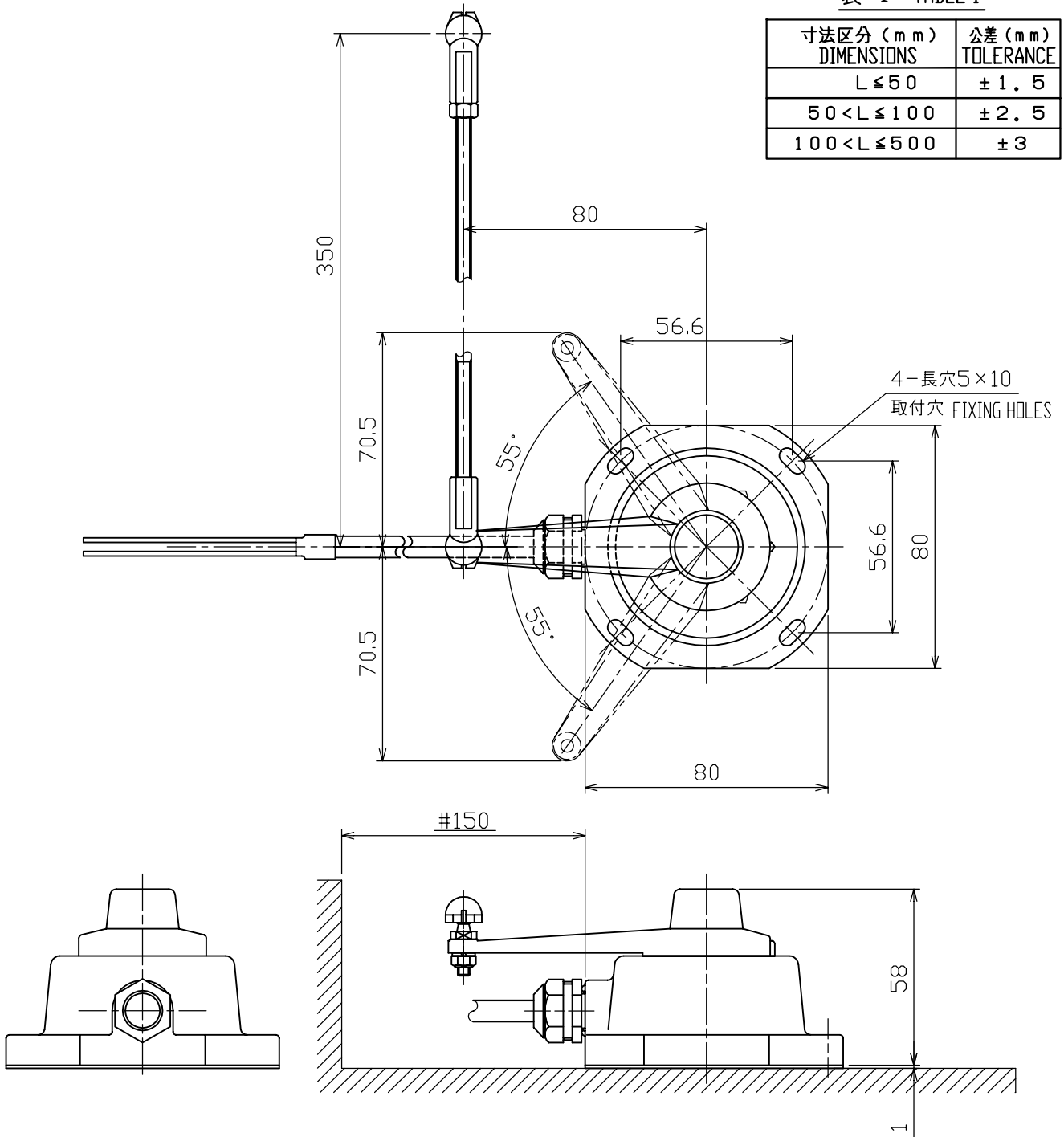

- 注 記 1) #印寸法は最小サービス空間寸法とする。  
 2) 指定外の寸法公差は表 1 による。  
 3) 取付用ネジは+トラスタッピングネジ呼び径 4×20 を使用のこと。  
 4) 質量にはケーブルを含まない。

- NOTE 1. #: MINIMUM SERVICE CLEARANCE.  
 2. TABLE 1 INDICATES TOLERANCE OF DIMENSIONS WHICH IS NOT SPECIFIED.  
 3. USE SELF-TAPPING SCREWS 4X20 FOR FIXING THE UNIT.  
 4. CABLE NOT INCLUDED IN MASS.

DRAWN	Apr. 14 '04 E. MIYOSHI	TITLE	FAP-6111
CHECKED	TAKAHASHI, T	名称	追従発信器
APPROVED	Y. Hatai	Navpilot-500/511	外寸図
SCALE	1/2	MASS	0.19 ±10% kg
DWG.No.	C7250-G04-B		NAME RUDDER REFERENCE UNIT OUTLINE DRAWING

表 1 TABLE 1

寸法区分 (mm) DIMENSION	公差 (mm) TOLERANCE
$L \leq 50$	$\pm 1.5$
$50 < L \leq 100$	$\pm 2.5$
$100 < L \leq 500$	$\pm 3$

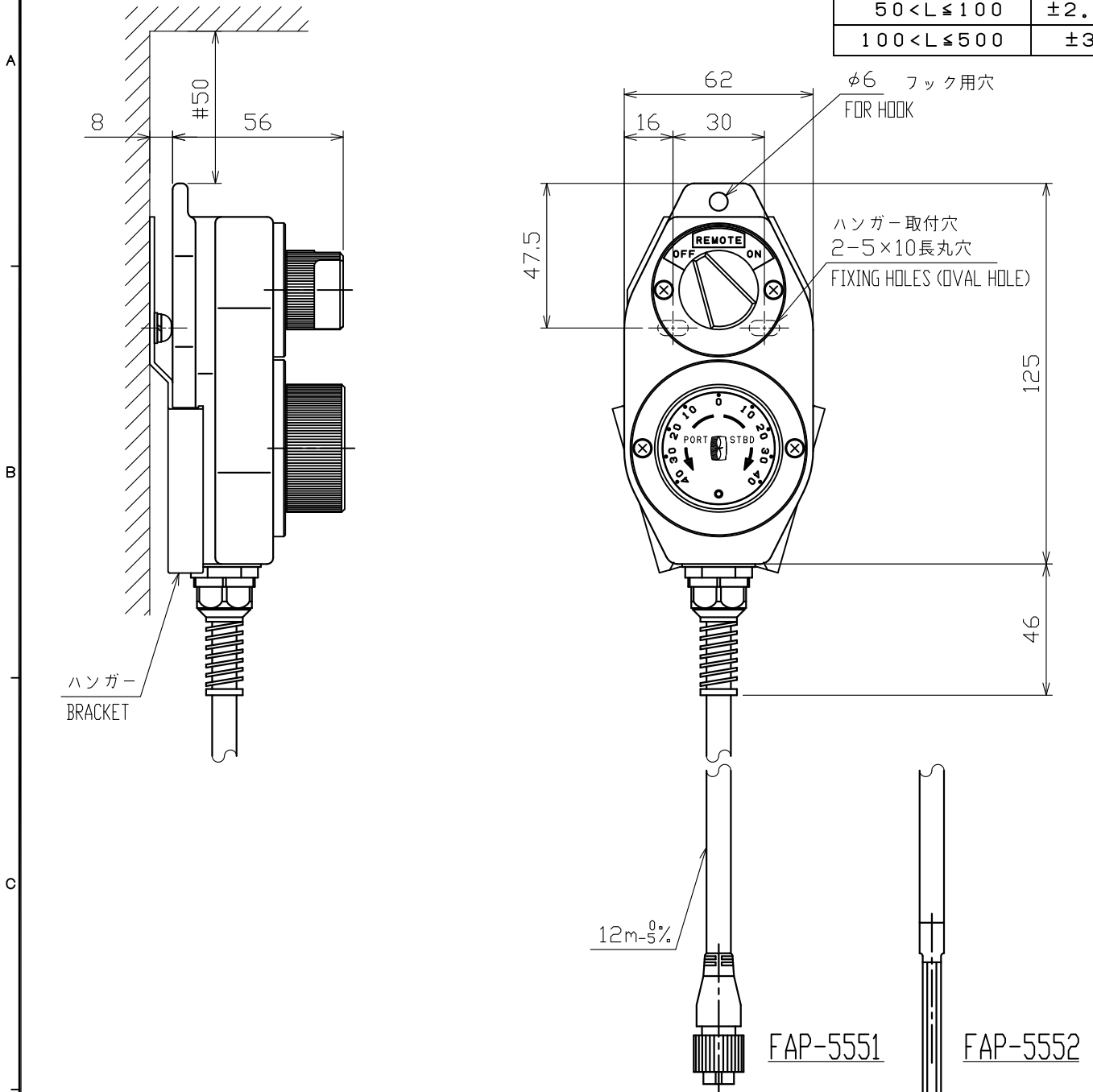

- 注 記 1) 指定外の寸法公差は表 1 による。  
 2) #印寸法は最小サービス空間寸法とする。  
 3) 取付用ネジは+マルモクネジ呼び径 4.8×20 を使用のこと。

- NOTE 1. TABLE 1 INDICATES TOLERANCE OF DIMENSIONS WHICH IS NOT SPECIFIED.  
 2. #: RECOMMENDED SERVICE CLEARANCE.  
 3. USE WOOD SCREWS  $\phi 4.8 \times 20$  FOR FIXING THE UNIT.

DRAWN	1/Nov/2011 T.YAMASAKI	TITLE	FAP-5551/5552
CHECKED	1/Nov/2011 H.MAKI	名称	遠隔管制器 (ダイヤル式)
APPROVED	1/Nov/2011 Y.NISHIYAMA		外寸図
SCALE	1/2	MASS	0.5 ±10% kg
			質量はケーブルを含まず。 MASS DOES NOT INCLUDE CABLE.
DWG.No.	C7235-G04-C	NAME	REMOTE CONTROLLER (DIAL TYPE) OUTLINE DRAWING

寸法区分 (mm) DIMENSION	公差 (mm) TOLERANCE
$L \leq 50$	$\pm 1.5$
$50 < L \leq 100$	$\pm 2.5$
$100 < L \leq 500$	$\pm 3$

表 1 TABLE 1

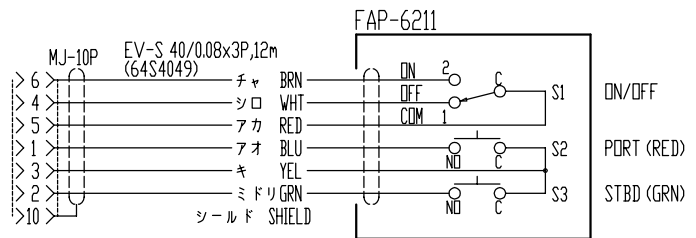
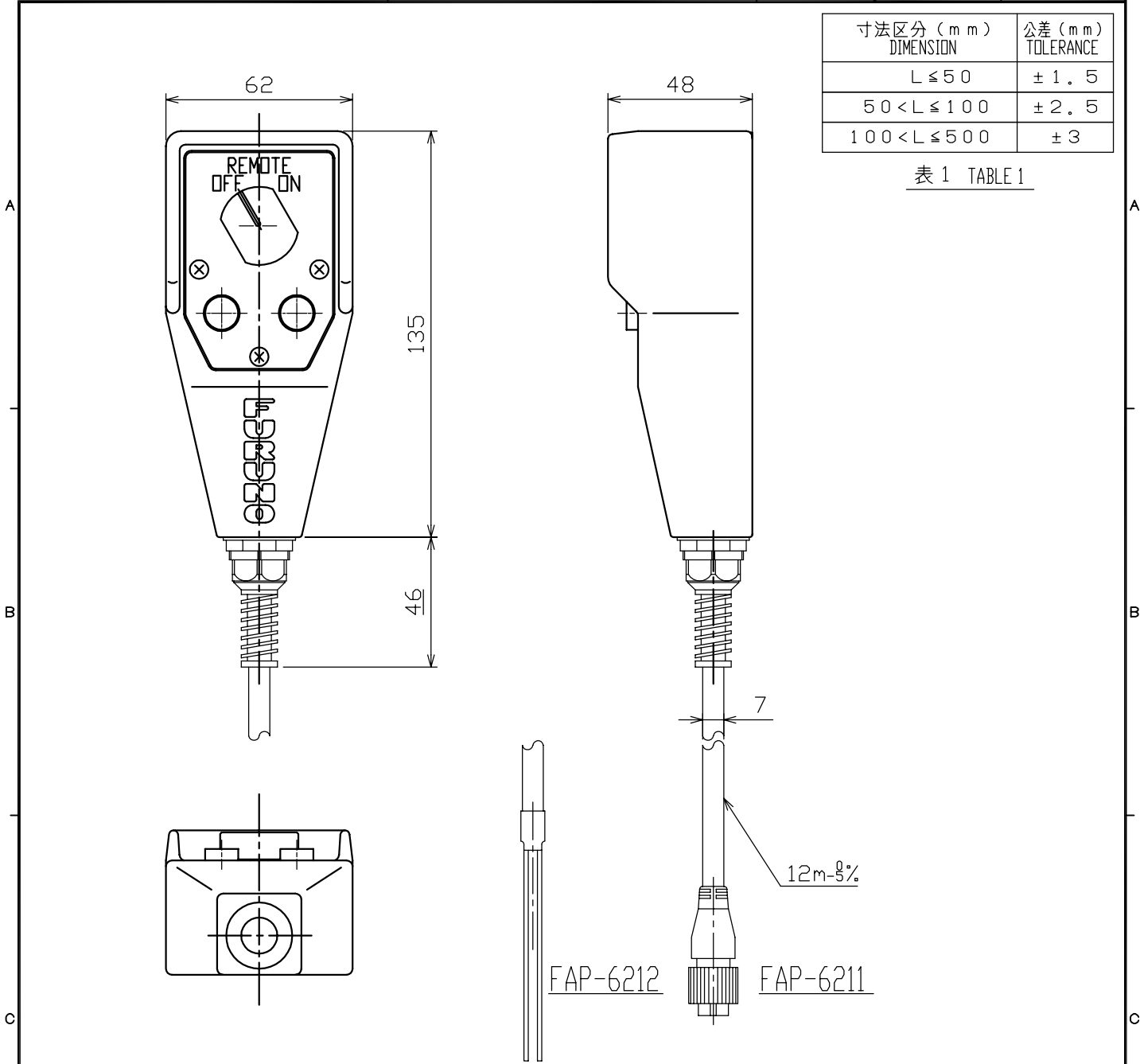

注 記 1) 指定外の寸法公差は表 1 による。

NOTE 1. TABLE 1 INDICATES TOLERANCE OF DIMENSION.

DRAWN Jun. 2 '03 T.YAMASAKI	TITLE FAP-6211/6212
CHECKED Jun. 2 '03 T.Matsuguchi	名称 遠隔管制器 (ボタン式)
APPROVED	外寸図
SCALE 1/2 MASS 0.5 ±10% kg 質量はケーブルを含まず。 MASS W/O CABLE.	NAME REMOTE CONTROLLER (BUTTON TYPE)
DWG.No. C7235-G05-B 64-015-350G-1	OUTLINE DRAWING

寸法区分 (mm) DIMENSION	公差 (mm) TOLERANCE
$L \leq 50$	$\pm 1.5$
$50 < L \leq 100$	$\pm 2.5$
$100 < L \leq 500$	$\pm 3$

表 1 TABLE 1

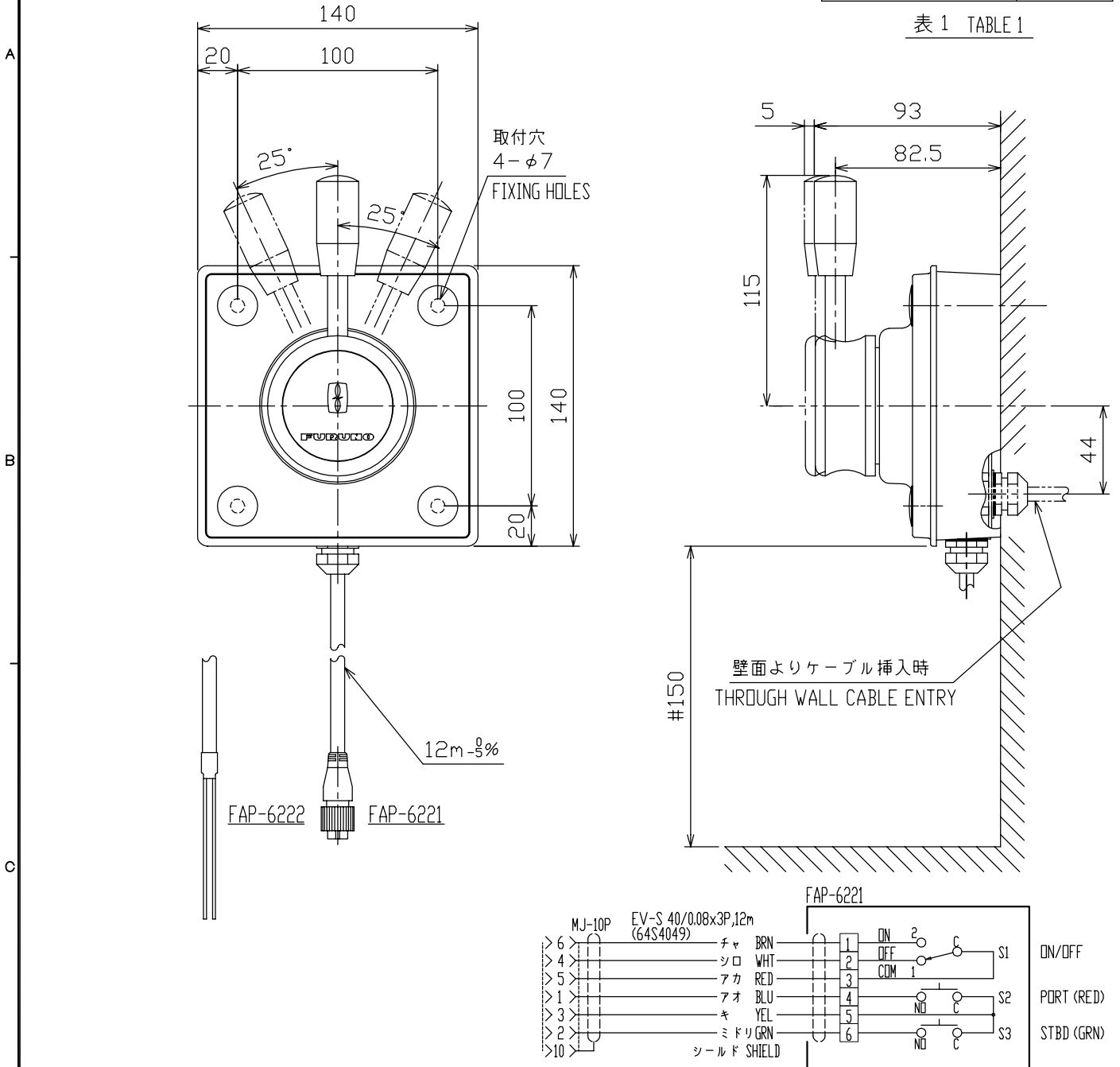

- 注 記 1) #印寸法は最小サービス空間寸法とする。  
 2) 指定外の寸法公差は表 1 による。  
 3) 取付用ネジは M6×50 ロックボルトを使用のこと。

- NOTE 1. #: RECOMMENDED SERVICE CLEARANCE.  
 2. TABLE 1 INDICATES TOLERANCE OF DIMENSIONS.  
 3. USE M6x50 BOLTS FOR FIXING THE UNIT.

DRAWN Jun. 2 '03 T.YAMASAKI	TITLE FAP-6221/6222
CHECKED Jun. 2 '03 T.Matsuguchi	名称 遠隔管制器 (レバー式)
APPROVED	外寸図
SCALE 1/3	MASS 1.8 ±10% kg
DWG.No. C7235-G06-B	質量はケーブルを含みます。 MASS W/O CABLE. 64-015-400G-1
	NAME REMOTE CONTROLLER (LEVER TYPE) OUTLINE DRAWING

寸法区分 (mm) DIMENSION	公差 (mm) TOLERANCE
$L \leq 50$	$\pm 1.5$
$50 < L \leq 100$	$\pm 2.5$
$100 < L \leq 500$	$\pm 3$

表 1 TABLE 1

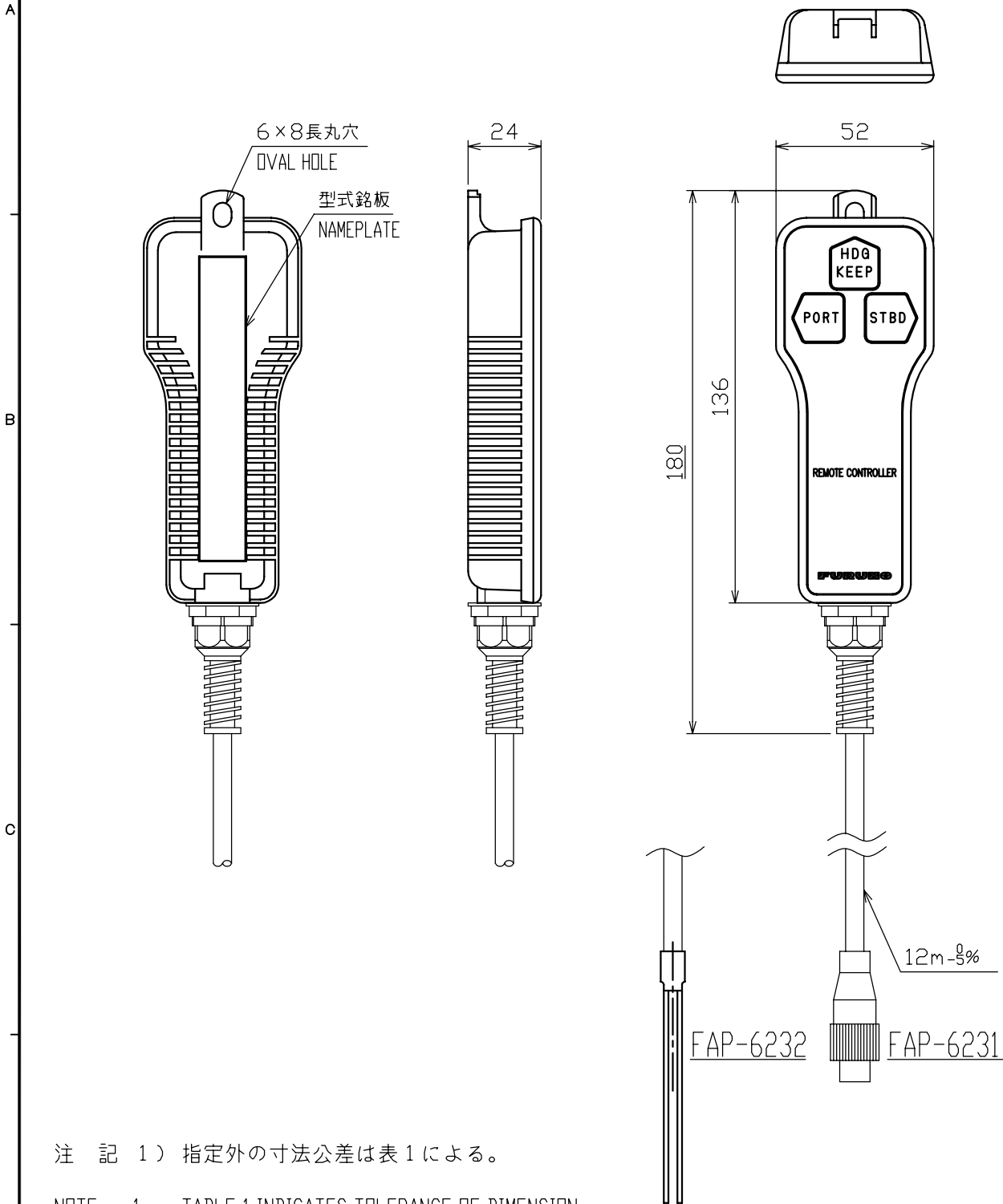

注 記 1) 指定外の寸法公差は表 1 による。

NOTE 1. TABLE 1 INDICATES TOLERANCE OF DIMENSION.

DRAWN Jun. 2 '03 T.YAMASAKI	TITLE FAP-6231/6232
CHECKED Jun. 2 '03 T.Matsuguchi	名称 遠隔管制器 (ドッジリモコン)
APPROVED Jun. 04 '03 Matsuguchi	外寸図
SCALE 1/2	NAME REMOTE CONTROLLER (DODGE TYPE)
MASS 0.1 ±10% kg	OUTLINE DRAWING
DWG.No. C7237-G06-B	質量はケーブルを含まず。 MASS W/O CABLE. 64-019-400G-1



A

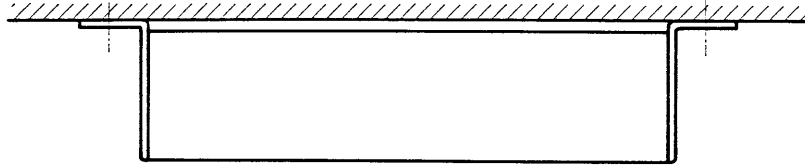

B

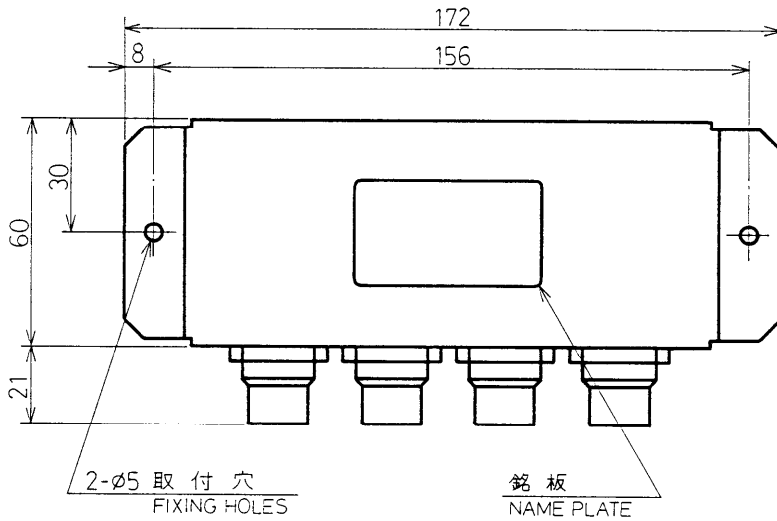

C

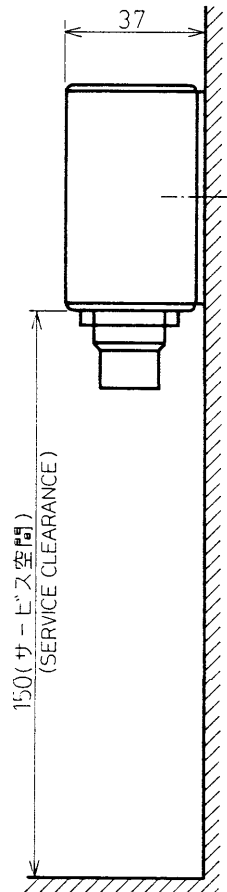

D

FAP-330

承認 APPROVED	品番 ITEM	品名 NAME	材質 MATERIAL	数量 Q'TY	図番 DWG. NO.	摘要 REMARKS
JUN. 3. '92 T. YAKKO		三角法 THIRD ANGLE PROJECTION				名称 TITLE リモコン分配器
検 CHECKED	JUN. 2. '92 N. SAITO	尺 SCALE	度 1/2		FAP-6800	DISTRIBUTOR
製 DRAWN	JUN. 2. '92 S. N. S. L.	重 WEIGHT	量 0.3 kg		図 DWG. NO.	C7235-G03-A



表 1 TABLE 1

寸法区分 (mm) DIMENSION	公差 (mm) TOLERANCE
L ≤ 50	± 1.5
50 < L ≤ 100	± 2.5
100 < L ≤ 500	± 3

- 注 記
- 取付には、M4×50寸切ボルト、M4平座金/バネ座金/ナットを使用のこと。
  - 印寸法は最小サービスクリアランスとする。
  - 指定外の寸法公差は表 1 による。

NOTE

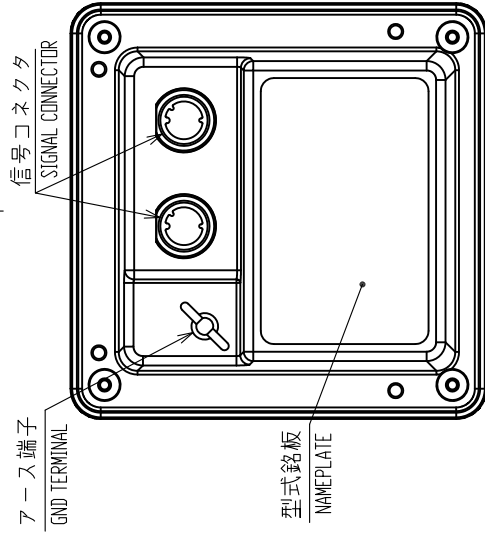
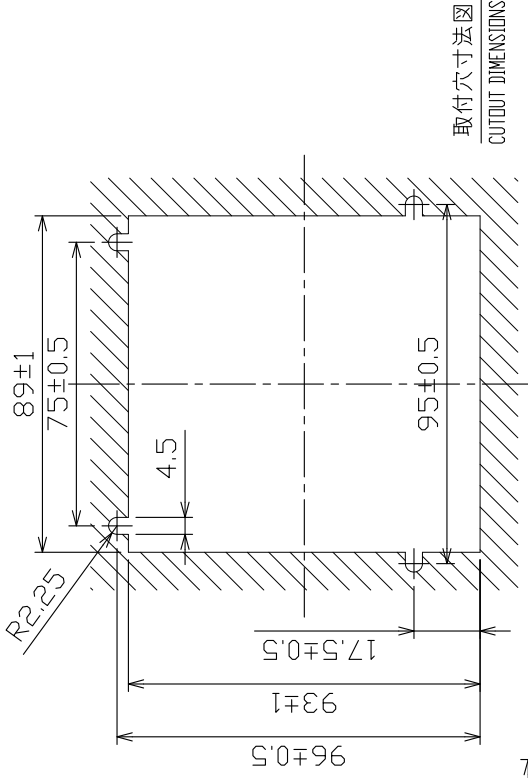
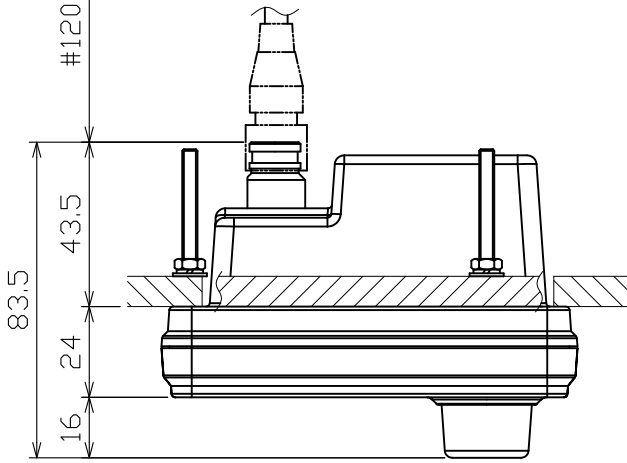
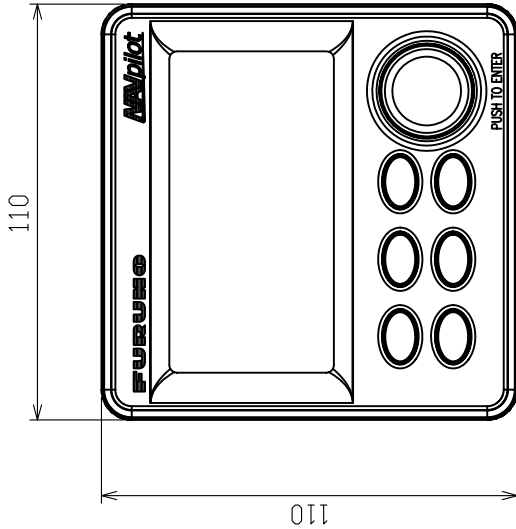
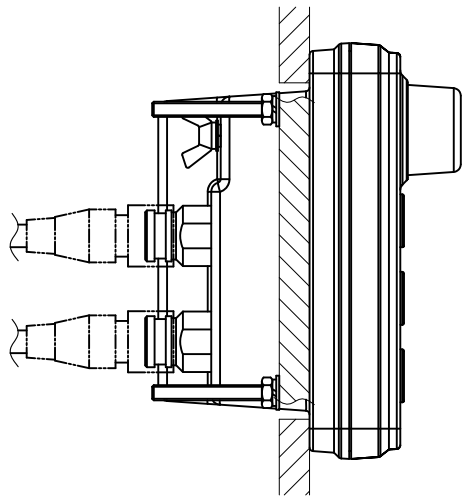
- USE M4X50 STUD BOLTS, M4 FLAT/SPRING WASHER AND NUTS FOR FIXING THE UNIT.
- #: MINIMUM SERVICE CLEARANCE.
- TABLE 1 INDICATES TOLERANCE OF DIMENSIONS WHICH IS NOT SPECIFIED.

DRAWN Sep. 6 '07	I. YAMASAKI	TITLE FAP-5011
CHECKED Sep. 6 '07	T. TAKENO	名称 操作部 (埋込装備)
APPROVED Sep. 7 '07	R. F. SUMI	外寸図
SCALE 1/2	MASS ±0.34 10% 質量公差 質量/カバーとケーブル	NAME CONTROL UNIT (FLUSH MOUNT)
DWG. No. C7250-605-C	REF. No. 64-026-100G-2	OUTLINE DRAWING

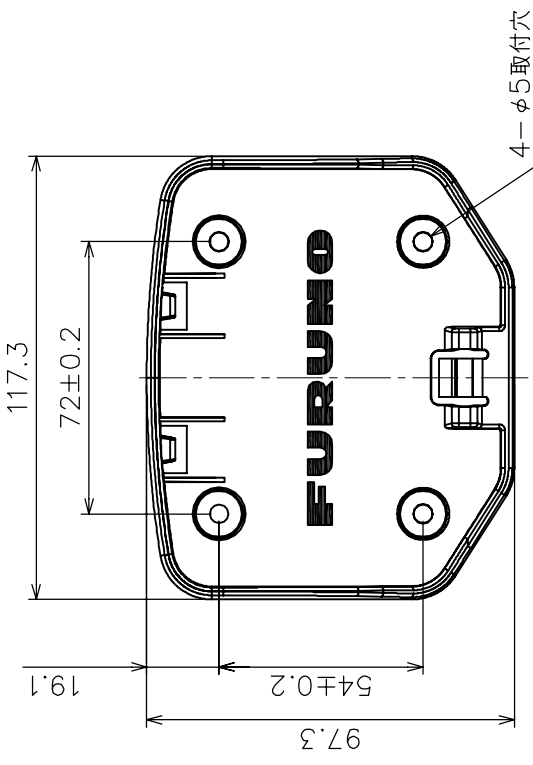

取付寸法図 (矢視A)  
FIXING DIMENSIONS (VIEW A)

表 1 TABLE 1

寸法区分 (mm) DIMENSIONS	公差 (mm) TOLERANCE
L ≤ 50	± 1.5
50 < L ≤ 100	± 2.5
100 < L ≤ 500	± 3

注記 1) 指定外の寸法公差は表 1 による。  
2) 取付用ネジはトラスタップネジ呼び径 4 × 20 を使用のこと。

NOTE 1. TABLE 1 INDICATES TOLERANCE OF DIMENSIONS WHICH IS NOT SPECIFIED.  
2. USE SELF-TAPPING SCREWS 4x20 FOR FIXING THE UNIT.

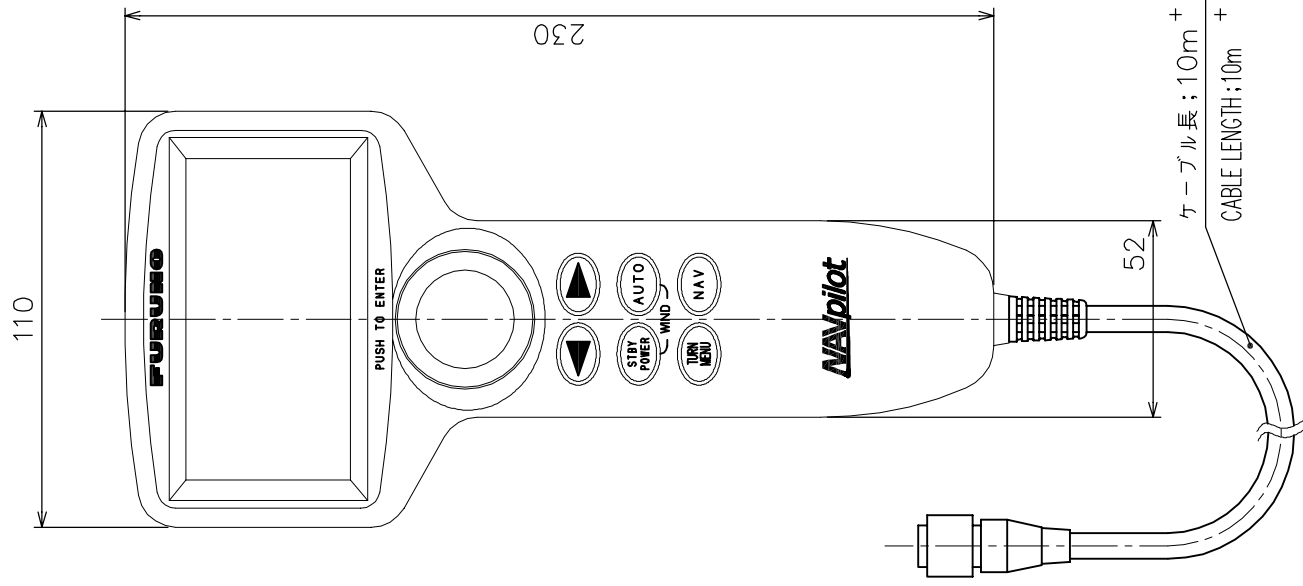
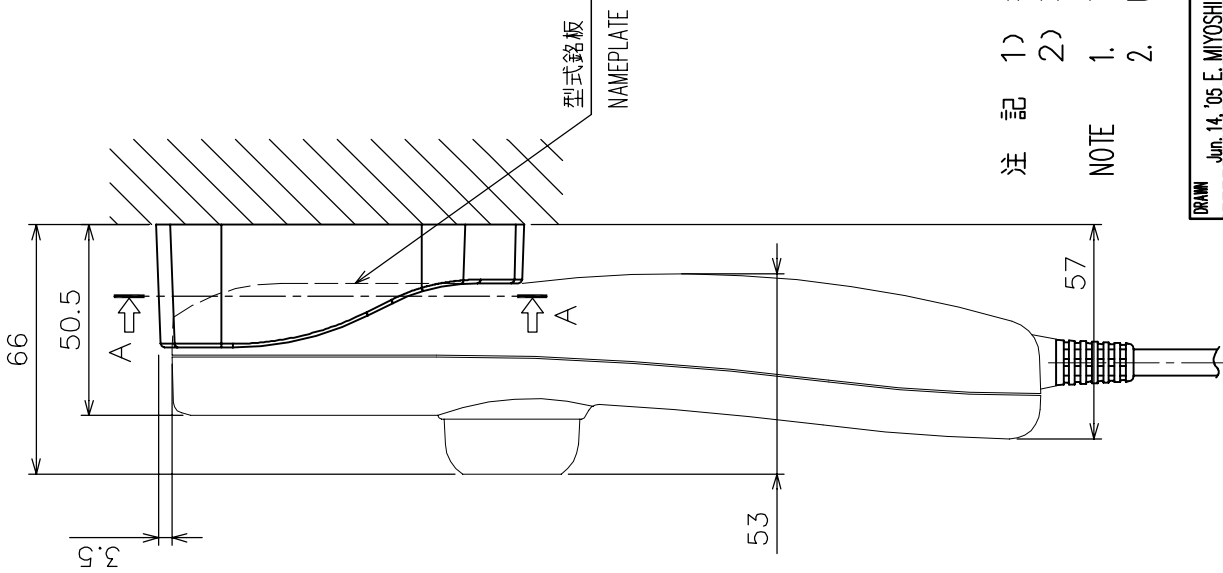

DRAWN Jun. 14, '05 E. MIYOSHI	TITLE FAP-5021
CHECKED TAKAHASHI, T	名称 操作部(壁掛タイプ)
APPROVED Y. Hatai	外寸図
SCALE 1/2 MASS ±10% CABLE NOT INCLUDED IN MASS.	NAME CONTROL UNIT (BULKHEAD MOUNT TYPE)
DWG.No. C7259-G01-A	REF.No. 64-027-100G-2
OUTLINE DRAWING	

表 1 TABLE 1

寸法区分 (mm) DIMENSIONS	公差 (mm) TOLERANCE
L ≤ 50	± 1.5
50 < L ≤ 100	± 2.5
100 < L ≤ 500	± 3

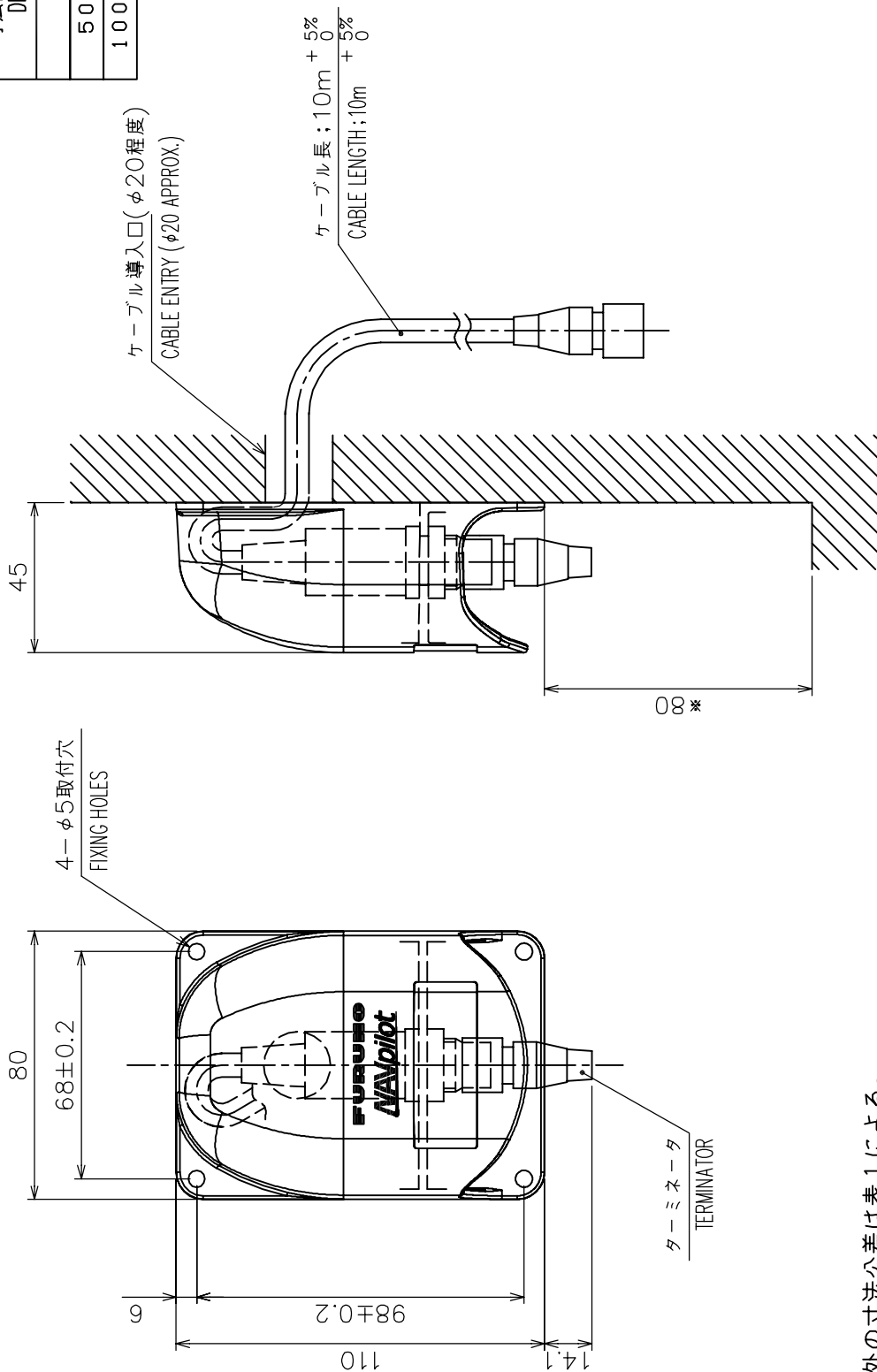

- 注 記
- 1) 指定外の寸法公差は表 1 による。
  - 2) \* 印寸法は最小サービスマン寸法とする。
  - 3) 取付用ネジはトラスタップネジ呼び径 4×20 を使用のこと。
- NOTE
1. TABLE 1 INDICATES TOLERANCE OF DIMENSIONS WHICH IS NOT SPECIFIED.
  2. #: MINIMUM SERVICE CLEARANCE.
  3. USE SELF-TAPPING SCREWS 4×20 FOR FIXING THE UNIT.

DRAWN JUN. 14, '05 E. MIYOSHI	TITLE FAP-6821
CHECKED TAKAHASHI, T	名 稱 接続箱(壁掛タイプ)
APPROVED Y. Hatai	外寸図
SCALE 1/2 MASS 0.057kg	NAME JUNCTION BOX(BULKHEAD MOUNT TYPE)
DWG.No. C7259-002-A	REF.No. 64-027-150G-2
	OUTLINE DRAWING

表 1 TABLE 1

寸法区分 (mm) DIMENSIONS	公差 (mm) TOLERANCE
$L \leq 50$	$\pm 1.5$
$50 < L \leq 100$	$\pm 2.5$
$100 < L \leq 500$	$\pm 3$
$500 < L \leq 1000$	$\pm 4$

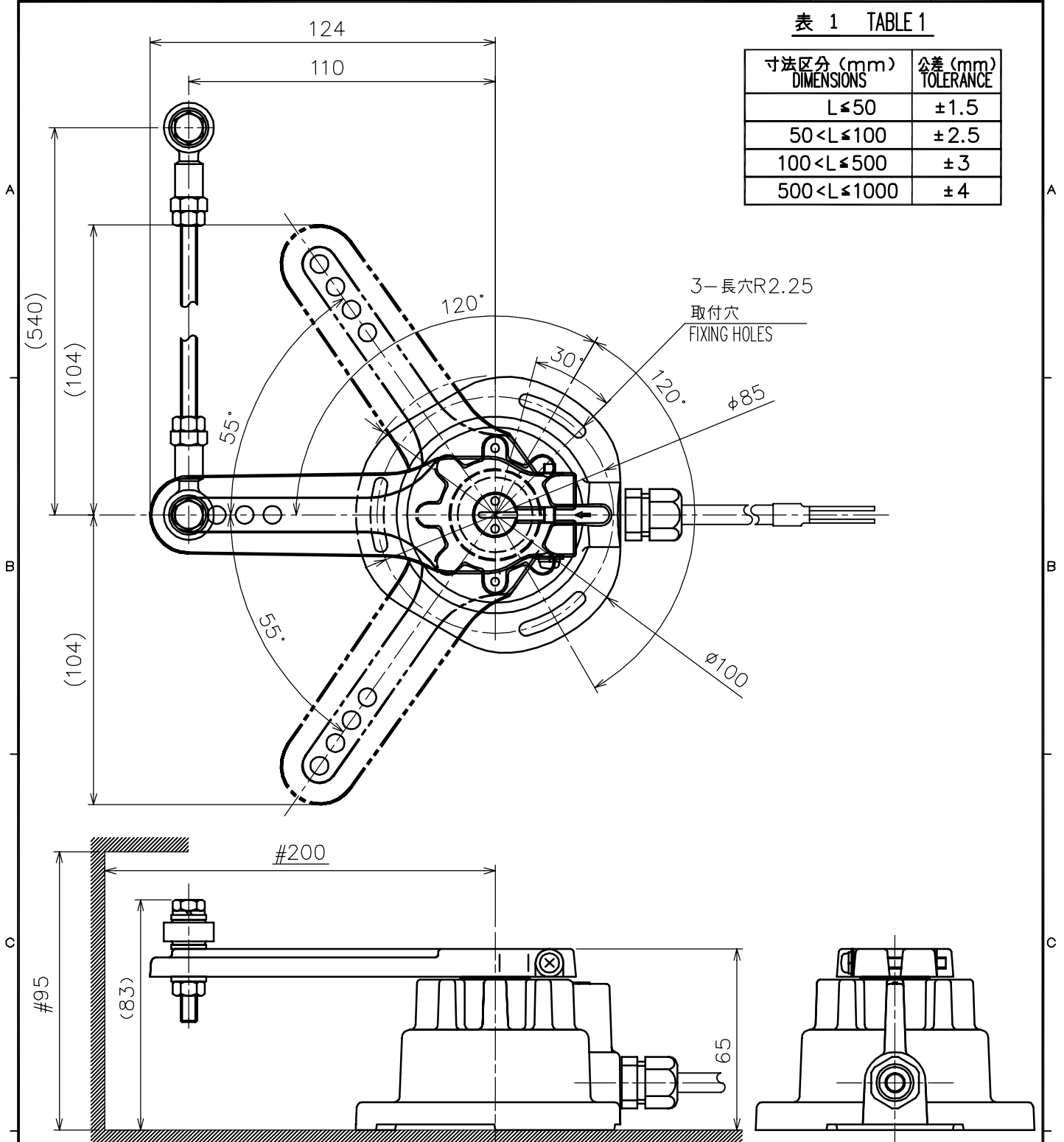

- 注 記 1) #印寸法は最小サービス空間寸法とする。  
 2) 指定外の寸法公差は表1による。  
 3) 取付用ネジは+トラスタップインネジ呼び径4×20を使用のこと。

- NOTE 1. #: MINIMUM SERVICE CLEARANCE.  
 2. TABLE 1 INDICATES TOLERANCE OF DIMENSIONS WHICH IS NOT SPECIFIED.  
 3. USE SELF-TAPPING SCREWS 4x20 FOR FIXING THE UNIT.

DRAWN Jan. 19, '06	E. MIYOSHI	TITLE FAP-6112
CHECKED	TAKAHASHI. T	名称 追従発信器
APPROVED	Y. Hatai	外寸図
SCALE 1/2	MASS $\pm 10\%$ 0.46 kg	NAME RUDDER REFERENCE UNIT
DWG.No. C7250-G07-A	REF.No. 64-024-460G-0	OUTLINE DRAWING

表1 TABLE 1

寸法区分 (mm) DIMENSIONS	公差 (mm) TOLERANCE
L ≤ 50	±1.5
50 < L ≤ 100	±2.5
100 < L ≤ 500	±3
500 < L ≤ 1000	±4

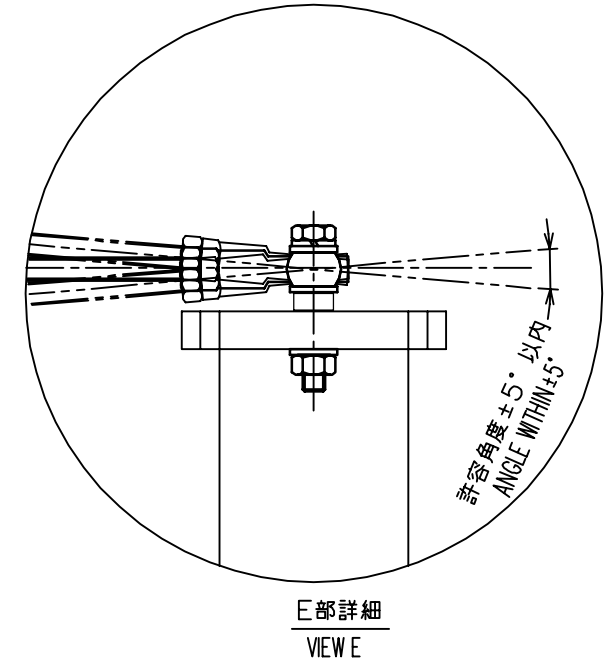
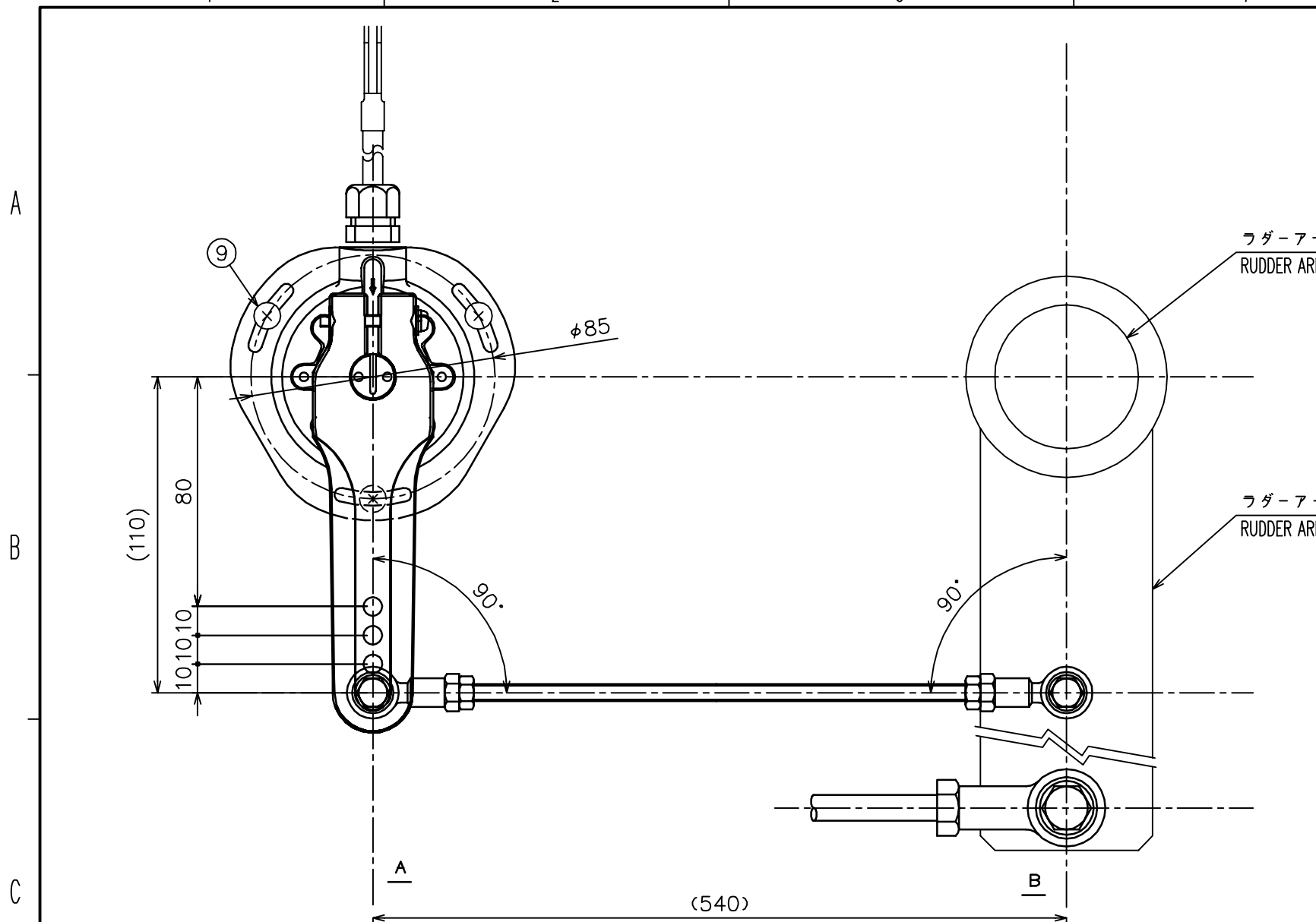

注記 1) A Bの軸線は平行のこと  
2) ラダーアーム上面とレンゲツボウは平行になるようにFAP-6112本体の高さを調整すること。

NOTE 1. AB AXIS SHOULD BE PARALEL.  
2. ADJUST HEIGHT OF FAP-6112 SO UPPER SURFACE OF RUDDER ARM IS PARALLEL WITH JOINT ROD.

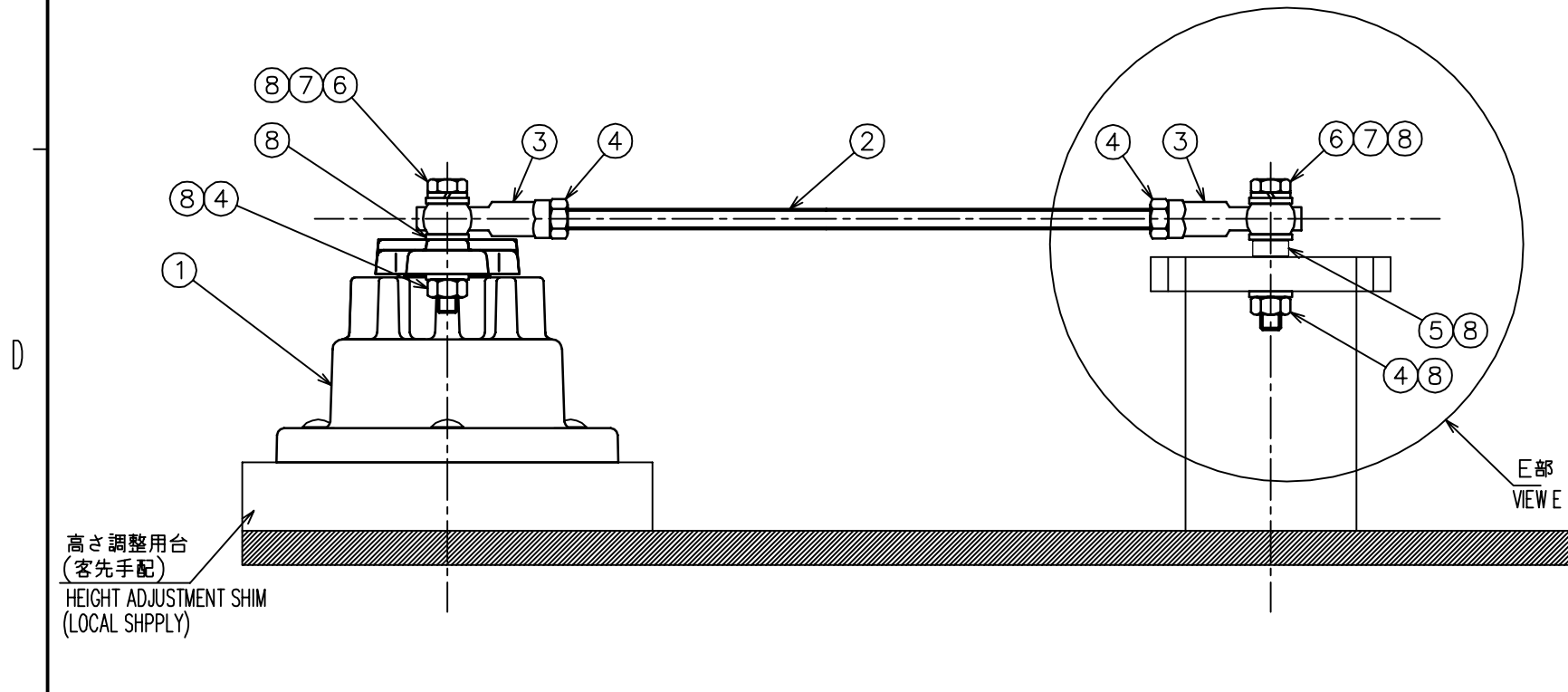

9	トラスタップピンネジ SELF-TAPPING SCREWS	SUS304	3		4x20 (工事材料) 4x20 (INSTALLATION MATERIALS)
8	平座金 FLAT WASHER	SUS304	6		M6 (工事材料) M6 (INSTALLATION MATERIALS)
7	バネ座金 SPRING WASHER	SUS304	2		M6 (工事材料) M6 (INSTALLATION MATERIALS)
6	六角ボルト HEX. BOLT	SUS304	2		M6x40 (工事材料) M6x40 (INSTALLATION MATERIALS)
5	カサアゲスペーサ SPACER	SUS304	1	64-024-4612	工事材料 INSTALLATION MATERIALS
4	六角ナット HEX. NUT	SUS304	4		M6 (工事材料) M6 (INSTALLATION MATERIALS)
3	ロッドエンドベアリング ROD END BEARING	SUS303	2	RBT6	工事材料 INSTALLATION MATERIALS
2	連結棒 JOINT ROD	SUS304	1	64-024-4606	工事材料 INSTALLATION MATERIALS
1	追従発信器本体 RUDDER REFERENCE UNIT		1	FAP-6112	
品番 ITEM	品名 NAME	材質 MATERIAL	数量 Q'TY	図番 DWG.NO.	摘要 REMARKS

DRAWN	Jan. 19, '06	E. MIYOSHI	TITLE	FAP-6112
CHECKED		TAKAHASHI, T	名称	追従発信器
APPROVED		Y. Hatai		装備図
SCALE	1/2	MASS ±10% 0.46 kg	質量は工事材料・ケーブルを含まず。 MASS DOES NOT INCLUDE INSTALLATION MATERIALS OR CABLE.	NAME
DWG No.	C7250-Y01-A	REF No.	64-024-461G-0	RUDDER REFERENCE UNIT INSTALLATION PROCEDURE

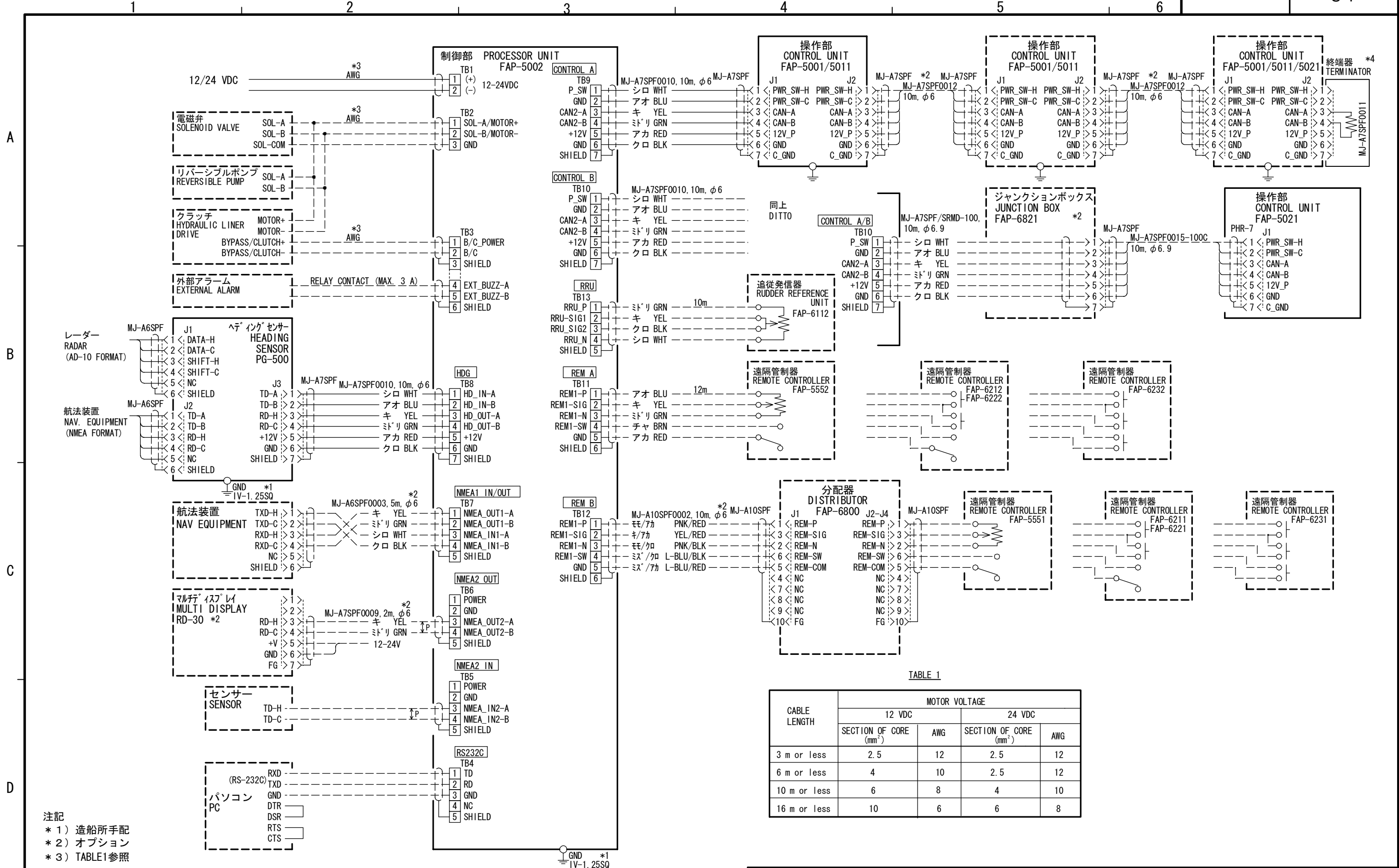

TABLE 1

CABLE LENGTH	MOTOR VOLTAGE			
	12 VDC		24 VDC	
	SECTION OF CORE (mm <sup>2</sup> )	AWG	SECTION OF CORE (mm <sup>2</sup> )	AWG
3 m or less	2.5	12	2.5	12
6 m or less	4	10	2.5	12
10 m or less	6	8	4	10
16 m or less	10	6	6	8

- 注記  
 \* 1) 造船所手配  
 \* 2) オプション  
 \* 3) TABLE1参照  
 \* 4) FAP-5021の場合は不要

- NOTE  
 \*1. SHIPYARD SUPPLY  
 \*2. OPTION  
 \*3. REFER TO TABLE1  
 \*4. NOT NECESSARY FOR FAP-5021.

DRAWN Dec. 6, '05 E. MIYOSHI	TITLE NAVpilot-500/511/520
CHECKED TAKAHASHI, T	名称 オートパイロット
APPROVED Y. Hatai	相互結線図
SCALE MASS kg	NAME AUTOPILOT
DWG No. C7250-C01- H	INTERCONNECTION DIAGRAM